

Moore Rezoning

ORDINANCE NO. 11-14

AN ORDINANCE AMENDING THE ZONING ORDINANCE TO CHANGE THE USE REGULATIONS ON PROPERTY OWNED BY DEAN MOORE LOCATED IN NORTH LIBERTY, IOWA, TO THOSE SET FORTH IN THE NORTH LIBERTY MUNICIPAL CODE FOR THE RM-12 MULTIFAMILY RESIDENTIAL AND RD-10 DUPLEX RESIDENTIAL DISTRICTS.

WHEREAS, the subject property is located within the North Liberty corporate city limits and

WHEREAS, the property is located in an area which is designated for future residential development in the North Liberty Comprehensive Plan, and

WHEREAS, the owner of the property, Dean Moore, has requested that the property be zoned to RM-12 Multifamily Residential and RD-10 Duplex Residential, and

WHEREAS, the RM-12 Multifamily Residential and RD-10 Duplex Residential districts provides for future development that is compatible with the future proposed development in the North Liberty Comprehensive Plan, and

WHEREAS, the Planning and Zoning Commission has reviewed the request and made the following recommendations:

- 1) That a statement approved by the City Planner is recorded by the owner prior to publication of the rezoning or with final plat documents including the following:
 - a) Informing future buyers of the existence and operating characteristics of the LL Pelling operations.
 - b) Informing future buyers that a substantial landscaped berm or other visual screening feature along the boundary with LL Pelling will be required by the city as part of any construction or site plans.
- 2) That the concept plan submitted with the application is generally followed; however, the city reserves the right to approve more or fewer units than shown.

NOW, THEREFORE, BE IT ORDAINED BY THE CITY COUNCIL OF THE CITY OF NORTH LIBERTY, IOWA, THAT:

Section 1. ZONING AMENDMENT. The property legally described as:
Tract #1 Rezone Parcel from C-2-A to RD-10

Beginning at the Southeast corner of Lot 5, Liberty Medical & Commerce, North Liberty, Iowa, in accordance with the Plat thereof recorded in Book 50, at Page 239, in the Records of the Johnson County Recorder's Office; Thence N89°36'39"W, along the South line of said Lot 5, a distance of 200.00 feet, to the Southwest corner thereof; Thence N00°08'33"E, along the West line of said Lot 5, a distance of 240.00 feet; Thence S89°51'27"E 200.00 feet, to a point on the East line of said Lot 5; Thence S00°08'33"W 240.86 feet to said Point of Beginning containing 1.10 acres (48,086 square feet), and subject to easements and restrictions of record.

Tract #2 Rezone Parcel from C-2-A to RM-12

Beginning at the Northeast corner of Lot 3, Liberty View, North Liberty, Iowa, in accordance with the Plat thereof recorded in Book 49, at Page 73, in the Records of the Johnson County Recorder's Office; Thence S00°08'33"W, along the East line of said Lot 3, and the East line of Lot 4 and Lot 5, Liberty Medical & Commerce, North Liberty, Iowa in accordance with the Plat thereof recorded in Book 50, at Page 239, in the Records of the Johnson County Recorder's Office 592.55 feet; Thence N89°51'27"W, 200.00 feet, to a point on the West line of said Lot 5 and Lot 4, Liberty Medical & Commerce, 250.33 feet; Thence Northwesterly, 235.13 feet, along the West line of Outlot "B", Liberty Medical and Commerce, and an arc of a 180.00 foot radius curve, concave Southwesterly, whose 218.77 foot chord bears N37°16'49"W, to the Northwest corner thereof, and the Southwest corner of said Lot 3, Liberty View; Thence N00°08'05"W, along the West line of said Lot 3, Liberty View, 168.47 feet, to the Northwest corner thereof; Thence S89°51'27"E, along the North line of said Lot 3, Liberty View 332.97 feet, to said Point of Beginning, containing 3.37 acres (146,932 square feet), and subject to easements and restrictions of record.

shall be classified and zoned to RM-12 Multifamily Residential and RD-10 Duplex Residential.

Section 2. ZONING MAP. It is hereby authorized and directed that the Zoning Map of the City of North Liberty, Iowa, be changed to conform to this amendment upon final passage, approval and publication of this ordinance as provided by law.

Section 3. RECORDATION. The City Clerk is hereby authorized and directed to record this ordinance at the Johnson County Recorder's office upon final passage and approval.

Section 4. REPEALER. All Ordinances and parts of ordinances in conflict with the provisions of this ordinance are hereby repealed.

Section 5. SEVERABILITY. If any section, provision or part of the ordinance shall be adjudged to be invalid or unconstitutional, such adjudication shall not affect the validity of the ordinance as a whole or any section, provision or part thereof not adjudged invalid or unconstitutional.

Section 6. EFFECTIVE DATE. This ordinance shall be in effect after its final passage, approval and publication as required by law.

* * * * *

First Consideration: September 27, 2011.

Second Consideration: October 11, 2011.

Third Consideration and adoption: _____.

PASSED AND APPROVED this ____ day of _____, 20__.

CITY OF NORTH LIBERTY, IOWA

BY: _____
Thomas A. Salm, Mayor

ATTEST:

Tracey Mulcahey, City Clerk

Drafted and approved as to form by City Attorney:

Scott C. Peterson, City Attorney

I certify that the forgoing was published as Ordinance No. _____ in the *North Liberty Leader* on the ____ day of _____, 2011.

Tracey Mulcahey, City Clerk

REZONING EXHIBIT

LOT 3 OF LIBERTY VIEW & LOTS 4, 5 AND OUTLOT "B" OF LIBERTY MEDICAL & COMMERCE NORTH LIBERTY, IOWA

PLAT PREPARED BY:
MMS CONSULTANTS, INC.
1917 S. GILBERT STREET
IOWA CITY, IOWA 52240

OWNER:
DEAN MOORE
P.O. BOX 1146
IOWA CITY, IOWA 52244

APPLICANT:
PRIME VENTURES
CONSTRUCTION, INC.
580 MADISON AVE. UNIT #3
NORTH LIBERTY, IOWA 52317

APPLICANT'S ATTORNEY:
MICHAEL J. PUGH
ONE S. GILBERT STREET
IOWA CITY, IOWA 52240

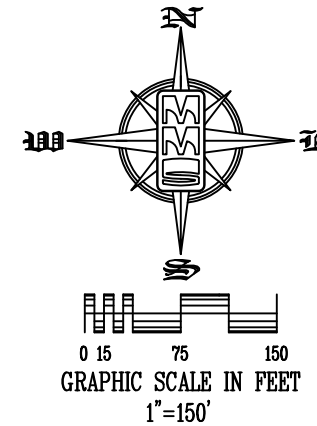

TRACT #1 REZONE PARCEL C2-A TO RD-10
BEGINNING at the Southeast corner of Lot 5, Liberty Medical & Commerce, North Liberty, Iowa, in accordance with the Plat thereof recorded in Book 50, at Page 239, in the Records of the Johnson County Recorder's Office; Thence N89°36'39"W, along the South line of said Lot 5, a distance of 200.00 feet, to the Southwest corner thereof; Thence N00°08'33"E, along the West line of said Lot 5, a distance of 240.00 feet; Thence S89°51'27"E, 200.00 feet, to a point on the East line of said Lot 5; Thence S00°08'33"W, 240.86 feet, to said POINT OF BEGINNING, containing 1.10 acres, (48,086 square feet), and subject to easements and restrictions of record.

TRACT #2 REZONE PARCEL C2-A TO RM-12
BEGINNING at the Northeast corner of Lot 3, Liberty View, North Liberty, Iowa, in accordance with the Plat thereof recorded in Book 49, at Page 73, in the Records of the Johnson County Recorder's Office; Thence S00°08'33"W, along the East line of said Lot 3, and the East line of Lot 4 and Lot 5, Liberty Medical & Commerce, North Liberty, Iowa, in accordance with the Plat thereof recorded in Book 50, at Page 239, in the Records of the Johnson County Recorder's Office, 592.55 feet; Thence N89°51'27"W, 200.00 feet, to a point on the West line of said Lot 5, Liberty Medical & Commerce; Thence N00°08'33"E, along the West line of said Lot 5 and Lot 4, Liberty Medical & Commerce, 250.33 feet; Thence Northwesterly, 235.13 feet, along the West line of Outlot "B", Liberty Medical & Commerce, and an arc of a 180.00 foot radius curve, concave Southwesterly, whose 218.77 foot chord bears N37°16'49"W, to the Northwest corner thereof, and the Southwest corner of said Lot 3, Liberty View; Thence N00°08'05"W, along the West line of said Lot 3, Liberty View, 168.47 feet, to the Northwest corner thereof; Thence S89°51'27"E, along the North line of said Lot 3, Liberty View, 332.97 feet, to said POINT OF BEGINNING, containing 3.37 acres, (146,932 square feet), and subject to easements and restrictions of record.

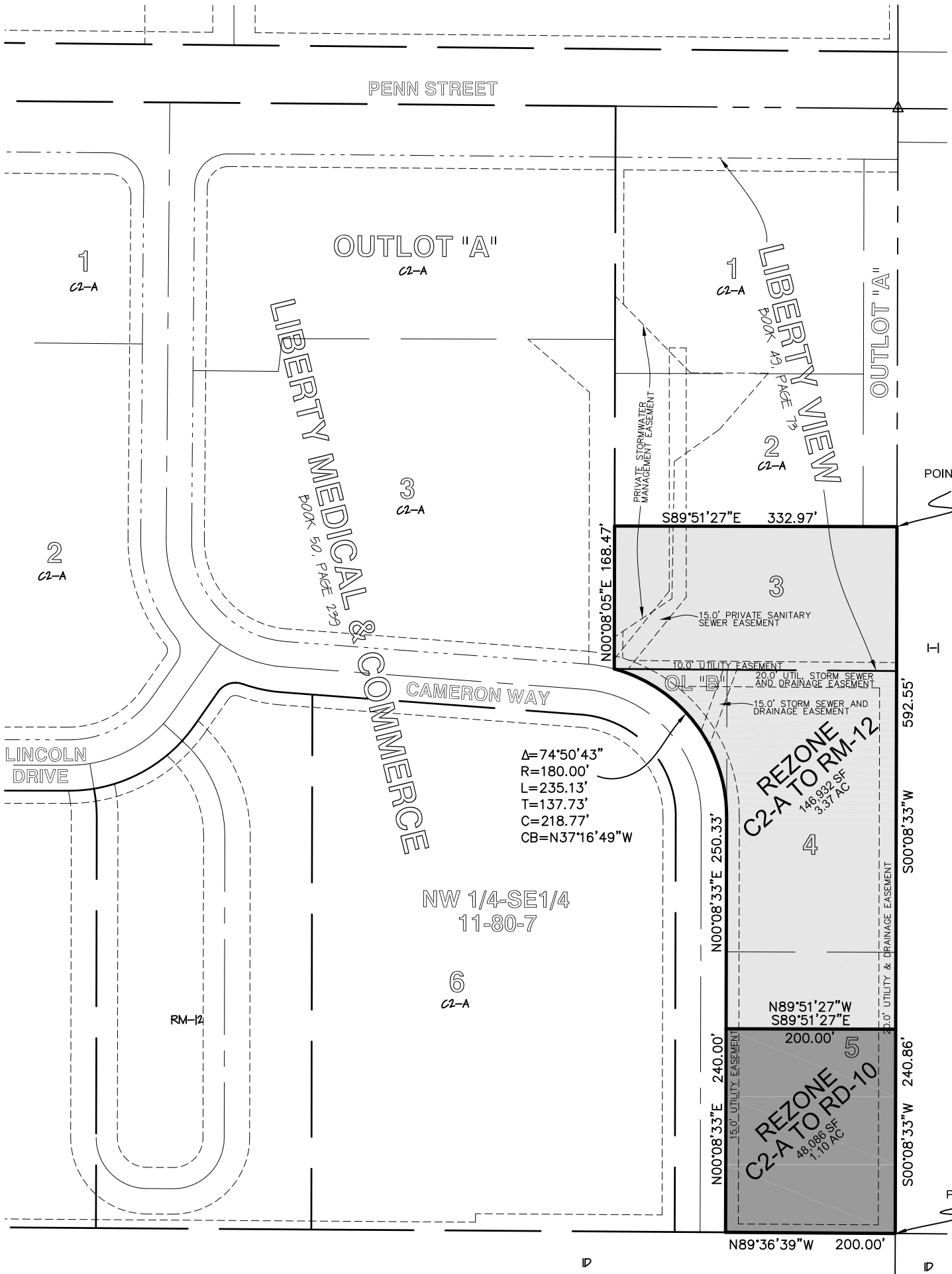

MMS

CIVIL ENGINEERS
LAND PLANNERS
LAND SURVEYORS
LANDSCAPE ARCHITECTS
ENVIRONMENTAL SPECIALISTS

1917 S. GILBERT ST.
IOWA CITY, IOWA 52240
(319) 351-8282

www.mmsconsultants.net

5741 C ST. SW SUITE C
CEDAR RAPIDS, IOWA 52404
(319) 841-5188

Date	Revision

REZONING EXHIBIT

LOT 3, LIBERTY VIEW AND
LOTS 4, 5 AND OUTLOT "B"
LIBERTY MEDICAL & COMMERCE
NORTH LIBERTY
JOHNSON COUNTY
IOWA

MMS CONSULTANTS, INC.

Date: 06-01-11	
Designed by: DAM	Field Book No:
Drawn by: JDM	Scale: 1"=150'
Checked by: JEL	Sheet No: 1
Project No: IC 3043017	of: 1