

Midwest Home Builders Rezoning

ORDINANCE NO. 11-16

AN ORDINANCE AMENDING THE ZONING ORDINANCE TO CHANGE THE USE REGULATIONS ON PROPERTY OWNED BY MIDWEST HOME BUILDERS LOCATED IN NORTH LIBERTY, IOWA, TO THOSE SET FORTH IN THE NORTH LIBERTY MUNICIPAL CODE FOR THE RM-8 MULTIFAMILY RESIDENTIAL DISTRICT.

WHEREAS, the subject property is located within the North Liberty corporate city limits and

WHEREAS, the property is located in an area which is designated for future residential development in the North Liberty Comprehensive Plan, and

WHEREAS, the owner of the property, Dean Moore, has requested that the property be zoned to RM-8 Multifamily Residential, and

WHEREAS, the RM-8 Multifamily Residential district provides for future development that is compatible with the future proposed development in the North Liberty Comprehensive Plan, and

WHEREAS, the Planning and Zoning Commission has reviewed the request and made the following recommendation:

- 1) That the developer/owners agree in a written document addressed to the city that development on the site will be generally consistent with and no denser than the concept plan.

NOW, THEREFORE, BE IT ORDAINED BY THE CITY COUNCIL OF THE CITY OF NORTH LIBERTY, IOWA, THAT:

Section 1. ZONING AMENDMENT. The property legally described as:

BEGINNING AT THE NORTHEAST CORNER OF LOT 2, PRIZLER'S FIRST ADDITION, NORTH LIBERTY, IOWA, IN ACCORDANCE WITH THE PLAT THEREOF RECORDED IN PLAT BOOK 35, AT PAGE 337, IN THE RECORDS OF THE JOHNSON COUNTY RECORDER'S OFFICE; THENCE S00°33'16"E, ALONG THE EAST LINE OF SAID LOT 2, A DISTANCE OF 274.00 FEET; THENCE S89°31'51"W, ALONG SAID EAST LINE, 257.00 FEET; THENCE S89°44'57"W, 26.17 FEET, TO A POINT ON THE WEST LINE OF SAID LOT 2; THENCE N00°33'16"W, ALONG SAID WEST LINE, 273.80 FEET, TO THE NORTHWEST

CORNER THEREOF; THENCE N89°29'26"E, ALONG THE NORTH LINE OF SAID LOT 2, A DISTANCE OF 283.16 FEET, TO SAID POINT OF BEGINNING, CONTAINING 1.78 ACRES, AND SUBJECT TO EASEMENTS AND RESTRICTIONS OF RECORD

shall be classified and zoned to RM-8 Multifamily Residential.

Section 2. ZONING MAP. It is hereby authorized and directed that the Zoning Map of the City of North Liberty, Iowa, be changed to conform to this amendment upon final passage, approval and publication of this ordinance as provided by law.

Section 3. RECORDATION. The City Clerk is hereby authorized and directed to record this ordinance at the Johnson County Recorder's office upon final passage and approval.

Section 4. REPEALER. All Ordinances and parts of ordinances in conflict with the provisions of this ordinance are hereby repealed.

Section 5. SEVERABILITY. If any section, provision or part of the ordinance shall be adjudged to be invalid or unconstitutional, such adjudication shall not affect the validity of the ordinance as a whole or any section, provision or part thereof not adjudged invalid or unconstitutional.

Section 6. EFFECTIVE DATE. This ordinance shall be in effect after its final passage, approval and publication as required by law.

* * * * *

First Consideration: October 25, 2011.

Second Consideration: November 8, 2011.

Third Consideration and adoption: _____.

PASSED AND APPROVED this ____ day of _____, 20____.

CITY OF NORTH LIBERTY, IOWA

BY: _____
Thomas A. Salm, Mayor

ATTEST:

Tracey Mulcahey, City Clerk

Drafted and approved as to form by City Attorney:

Scott C. Peterson, City Attorney

I certify that the forgoing was published as Ordinance No. _____ in the *North Liberty Leader* on the ____ day of _____, 2011.

Tracey Mulcahey, City Clerk

ZONING EXHIBIT
LOT 2, PRIZLER'S FIRST ADDITION
 NORTH LIBERTY, JOHNSON COUNTY, IOWA

LOT 1
 RM-21
 JEFFERSON ADDITION
 PART ONE

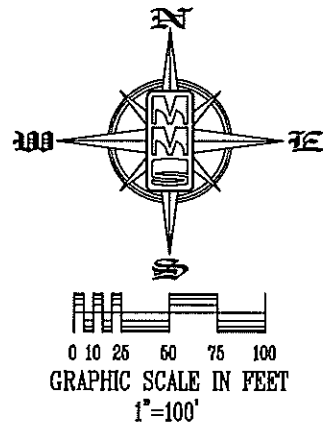

REZONE FROM RS-4 TO RM-8

BEGINNING AT THE NORTHEAST CORNER OF LOT 2, PRIZLER'S FIRST ADDITION, NORTH LIBERTY, IOWA, IN ACCORDANCE WITH THE PLAT THEREOF RECORDED IN PLAT BOOK 35, AT PAGE 337, IN THE RECORDS OF THE JOHNSON COUNTY RECORDER'S OFFICE; THENCE S00°33'16"E, ALONG THE EAST LINE OF SAID LOT 2, A DISTANCE OF 274.00 FEET; THENCE S89°31'51"W, ALONG SAID EAST LINE, 257.00 FEET; THENCE S89°44'57"W, 26.17 FEET, TO A POINT ON THE WEST LINE OF SAID LOT 2; THENCE N00°33'16"W, ALONG SAID WEST LINE, 273.80 FEET, TO THE NORTHWEST CORNER THEREOF; THENCE N89°29'26"E, ALONG THE NORTH LINE OF SAID LOT 2, A DISTANCE OF 283.18 FEET, TO SAID POINT OF BEGINNING, CONTAINING 1.78 ACRES, AND SUBJECT TO EASEMENTS AND RESTRICTIONS OF RECORD.

OUTLOT "A"
 RM-21
 JEFFERSON ADDITION
 PART THREE

SURVEY OF NE 1/4, 12-80-7
 RM-21

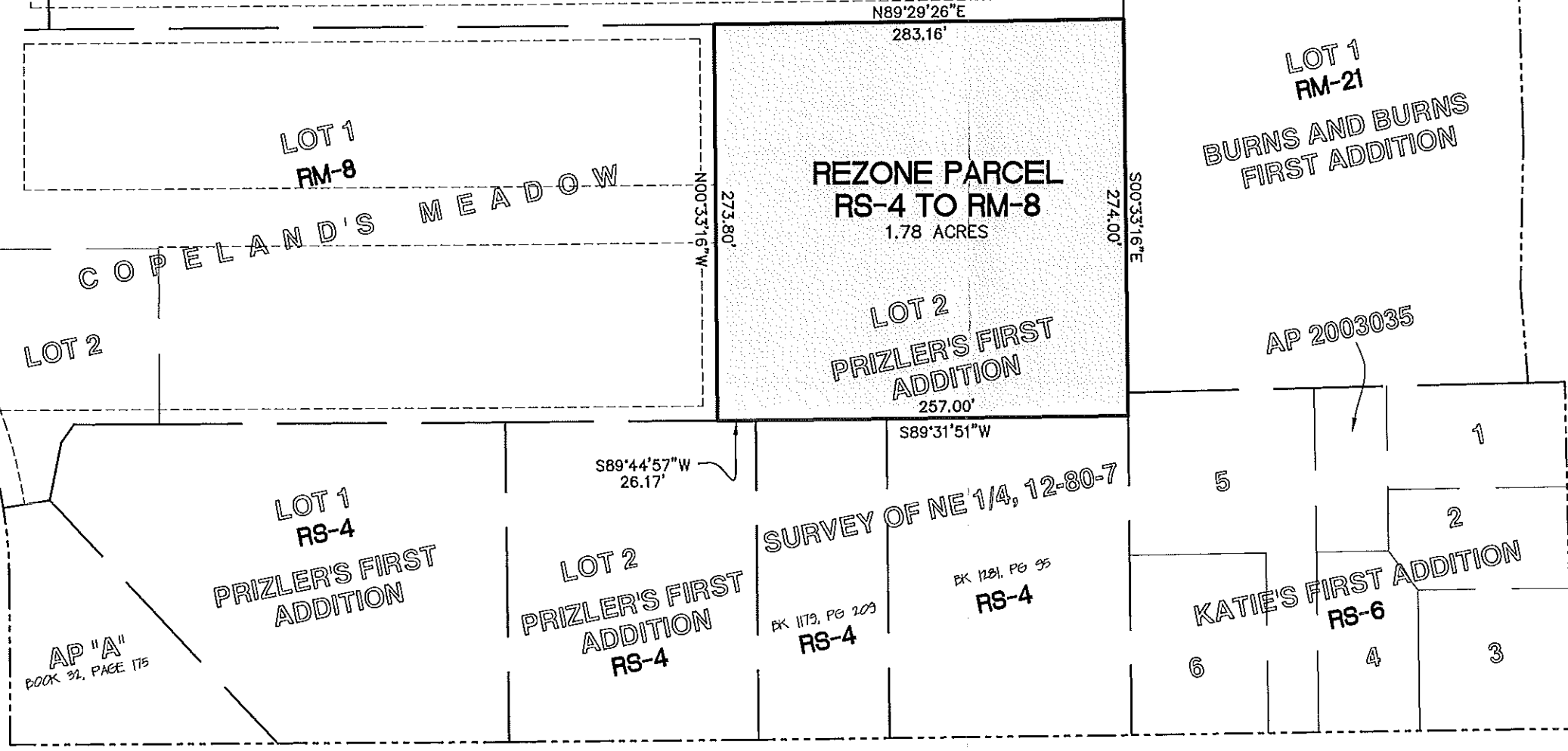

N FRONT STREET

N DUBUQUE STREET

W PENN STREET

MMS

CIVIL ENGINEERS
 LAND PLANNERS
 LAND SURVEYORS
 LANDSCAPE ARCHITECTS
 ENVIRONMENTAL SPECIALISTS

1917 S. GILBERT ST.
 IOWA CITY, IOWA 52240
 (319) 351-8282

www.mmsconsultants.net

5741 C ST. SW SUITE C
 CEDAR RAPIDS, IOWA 52404
 (319) 841-5188

Date	Revision

ZONING EXHIBIT

**LOT 2, PRIZLER'S
 FIRST ADDITION**
 NORTH LIBERTY
 JOHNSON COUNTY
 IOWA

MMS CONSULTANTS, INC.

Date:	08/01/11
Designed by:	DAM
Field Book No:	
Drawn by:	JDM
Scale:	1"=100'
Checked by:	DAM
Sheet No:	1
Project No:	IC 6886013
of:	1

RD-10

RS-6
 TRIANGLE PLACE ADDITION

RS-6
 NORTHFIELD SUBDIVISION