

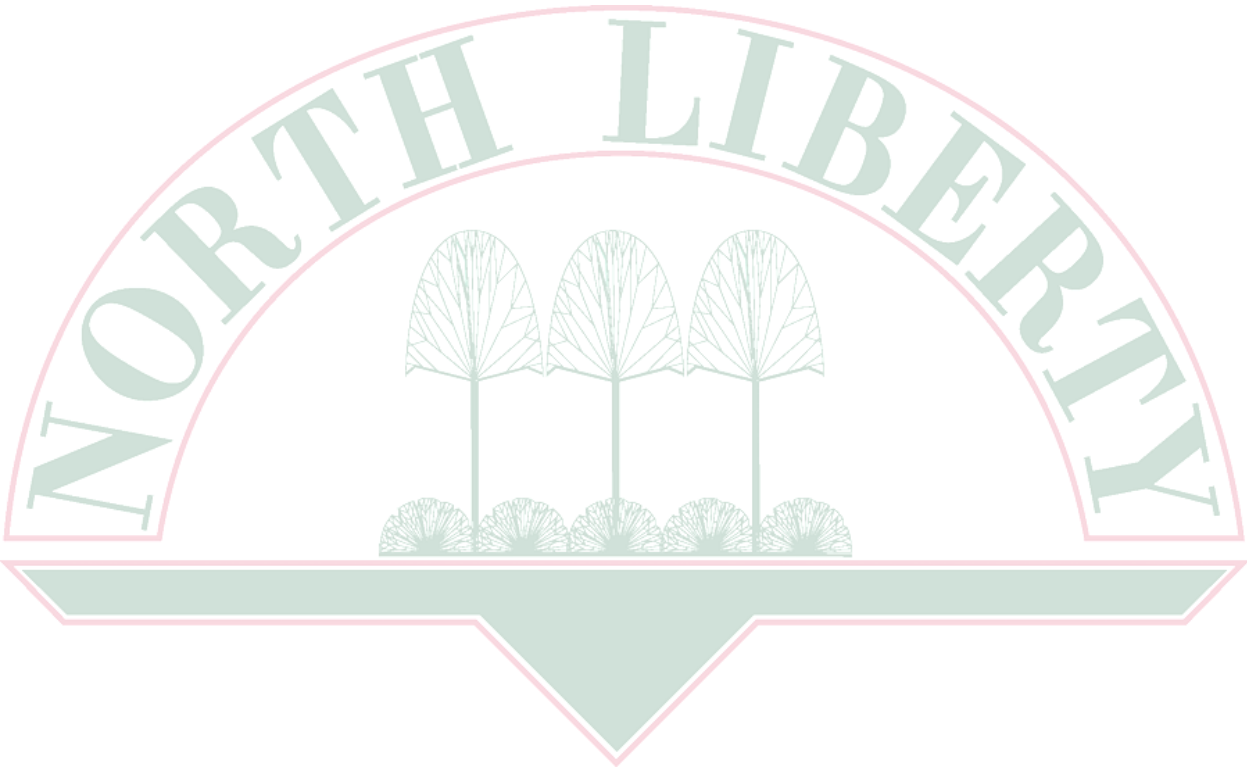

January 24, 2017

North Liberty
City Council
Regular Session

City Administrator Memo





City Council Memo

for January 24, 2017

from the desk of Ryan C. Heiar

Meetings & Events

Tuesday, Jan 24 at 6:30p.m.

City Council

Monday, Jan 30 at 4:00p.m.

Joint Government Meeting

Tuesday, Jan 31 at 6:30p.m.

City Council Budget

Workshop

Thursday, Feb 2 at 7:00p.m.

Parks & Recreation

Commission

Monday, Feb 6 at 6:00p.m.

Communications Commission

Tuesday, Feb 7 at 6:30p.m.

Planning Commission

Tuesday, Feb 14 at 6:30p.m.

City Council

Consent Agenda

The following items are on the consent agenda and included in your packet:

- City Council Minutes (01/10/17 & 01/17/17)
- Claims
- December Revenues
- Liquor License Renewals
 - El Cactus
 - Johnny's
 - The Station
- Phase I Water System Improvements, Division 1 Water Treatment Plant, Portzen Construction, \$180,671.91
- Wastewater Treatment Plant Project, Change Order #10, Tricon Construction Group, \$27,587.25

NOTE: The ownership issues with El Cactus have been resolved and properly filed at the state level.

Phase I Water System Improvements, Division 2 – Water Main

The agenda includes a public hearing and resolution regarding the plans and specification for the Phase I Water System Improvements, Division 2; Raw Water Main project. A project overview map is included in your packet and a complete set of plans are available for review at City Hall. Staff recommends approval of the plans specifications. Bids for this project are due on February 7 and it is anticipated that an award recommendation will be on the February 14 agenda.

Ryan C. Heiar, City Administrator

rheiar@northlibertyiowa.org • office (319) 626-5700 • fax (319) 626-3288 • cell (319) 541-8404

North Liberty Road Project

Interest in the North Liberty Road project was high as six bids were received. A summary of the bids can be found to the right and a detailed breakdown is included in your packet. The low bid was submitted by Metro Pavers, Inc. of Iowa City, and was approximately \$595k below the engineer's estimate. Also included in your packet is a letter from Shive Hattery stating that the submitted low bid is complete and accurate and they are recommending approval of the bid to Metro Pavers, Inc.

North Liberty Road Improvements - Bid Summary	
Engineer's Estimate	\$2,845,320.58
Metro Pavers, Inc.	\$2,250,623.32
Streb Construction	\$2,490,509.72
BWC Excavating, LC	\$2,853,415.00
Horsfield Construction	\$2,877,429.52
Eastern Iowa Excavating & Concrete	\$2,878,024.98
Portzen Construction	\$2,948,989.13

Logan Supply

This request is to approve a site plan located west of Interstate I-380, near the south end of Stoner Court. The site, zoned I1 (Light Industrial), is proposed to be developed for a contractors' supply store. The developer has worked well with staff and is presenting a very nice looking facility in our industrial area. Staff and the Planning Commission recommend approval of the site plan.

Parking Resolution

The City has received complaints from North Liberty Living Center residents about parking on Ashley Court that makes access to the facility difficult for some drivers, particularly delivery drivers. Additionally, the City's new bus route includes Ashley Court and is impacted by parking near the Living Center. In examining the bigger picture, Ashley Court is a long dead-end street (planned to continue across the CRANDIC tracks in the future) with high-density uses, and the staff review committee concluded that it is appropriate to recommend removal on the entire south side of the street. Letters were sent to all adjoining property owners on both sides of the street on December 22 asking for input on that proposal, and no responses were received by the deadline date of January 17.

North Liberty Cafeteria Plan

The resolution and related agreement in your packet will allow our employees to contribute the maximum amount allowed by federal law into their Health Flex Spending Account. When this program was established for City employees in 2012, the maximum contribution was \$2,500 and had been for some time. In 2015 the maximum contribution increased to \$2,550 and this year it increased to \$2,600. The proposed agreement says that employees may contribute the maximum allowed by the IRS – it does not specify a dollar amount – so future amendments to this agreement, for this purpose would not be required. To further clarify, the contribution amounts come directly from the staff through a payroll deduction. This is not a new benefit and the City will not be paying more money.

Mayoral Vacancy

Included in your packet is a memo from City Attorney Scott Peterson regarding the options for appointing or holding a special election for the Mayor position. Whatever option is decided, it can be approved by a motion/second/voice vote – a resolution is not needed. Staff is seeking direction from the group so that the Mayoral replacement process can begin.

Agenda

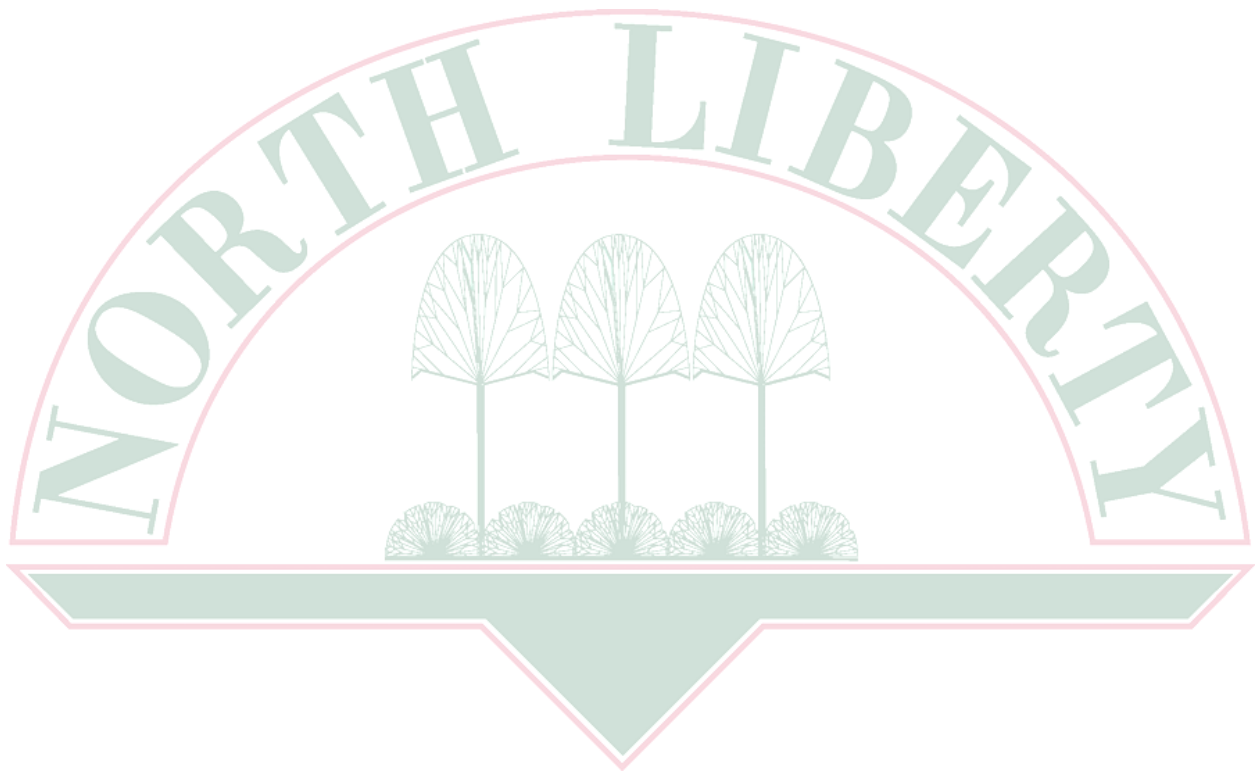



AGENDA

North Liberty City Council
January 24, 2017
Regular Session
6:30 p.m.
City Council Chambers

1. Call to order
2. Roll call
3. Approval of the Agenda
4. Consent Agenda
 - A. City Council Minutes, Regular Session, January 10, 2017
 - B. City Council Minutes, Special Session, January 17, 2017
 - C. Claims
 - D. December Revenues
 - E. Liquor License Renewal, El Cactus, Class C Liquor License with Sunday sales endorsement (with updated ownership)
 - F. Liquor License Renewal, Johncy's, Class E Liquor License with Sunday Sales endorsement
 - G. Liquor License Renewal, The Station LLC, Class E Liquor License with Sunday Sales and Growler fill endorsements
 - H. Phase I Water System Improvement, Division I Water Treatment Plant, Portzen Construction, Pay Application Number 3, \$180,671.91
 - I. NL WWTP Phase 2 Project, Tricon Construction, Change Order #10, \$27,587.25
5. Public Comment
6. City Planner Report
7. City Engineer Report
8. City Attorney Report
9. Assistant City Administrator Report

10. City Administrator Report
11. Mayor Pro Tem Report
 - A. Statement of support for the Guard and Reserve
12. Phase I Water System Improvements, Division II – Water Mains
 - A. Public Hearing regarding proposed plans, specifications, form of contract and estimate of cost
 - B. Resolution Number 2017-05, A Resolution finally approving and confirming plans, specifications, form of contract and estimate of cost for the Phase I Water System Improvements Division II – Water Mains
13. North Liberty Road Project
 - A. Resolution Number 2017-06, A Resolution accepting the bid and authorizing execution of the contract for the North Liberty Road Improvements Project, North Liberty, Iowa
14. Logan Contractor Supply Site Plan
 - A. Staff and Commission Recommendation
 - B. Applicant presentation
 - C. Resolution Number 2017-07, A Resolution approving the Development Site Plan for Lot 2, Resubdivision of Lot 13, I-380 Industrial Park, North Liberty, Iowa
15. Parking Resolution
 - A. Resolution Number 2017-08, A Resolution approving parking control devices in the City of North Liberty, Iowa
16. North Liberty Cafeteria Plan
 - A. Resolution Number 2017-09, A Resolution approving the amended Cafeteria Plan for employees in the City of North Liberty, Iowa
17. Mayoral Vacancy
 - A. Discussion and possible action regarding Mayoral vacancy
18. FY 18 Budget Discussion
19. Old Business
20. New Business
21. Adjournment

Consent Agenda

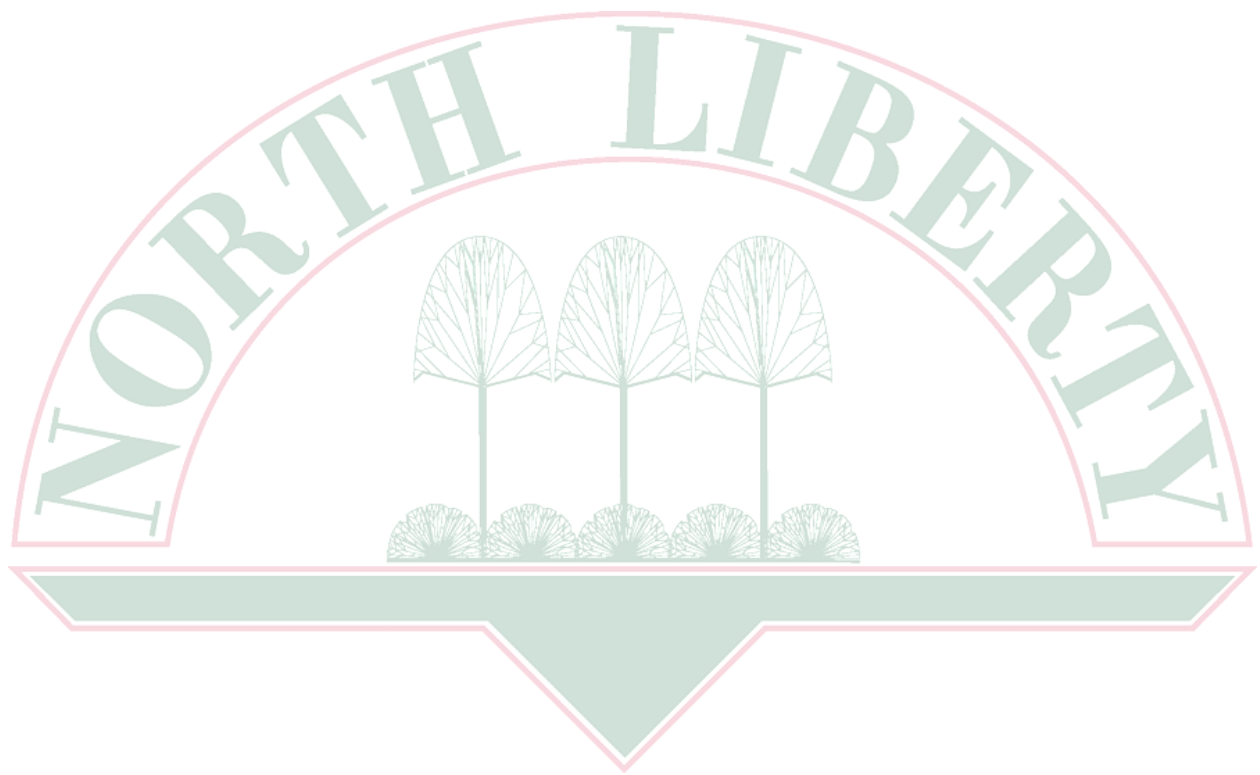



Minutes

North Liberty City Council
January 10, 2017
Regular Session

Call to order

Mayor Pro Tem Terry Donahue called the January 10, 2017 Regular Session of the North Liberty City Council to order. Council members present: Terry Donahue, Chris Hoffman, Jim Sayre, Annie Pollock; absent - Brian Wayson.

Others present: Ryan Heiar, Tracey Mulcahey, Kevin Trom, Dean Wheatley, Megan Benischek, Steve Kuhl and other interested parties.

Approval of the Agenda

Hoffman moved, Pollock seconded to approve the agenda. The vote was all ayes. Agenda approved.

Consent Agenda

Sayre moved, Pollock seconded to approve the Consent Agenda including the City Council Minutes from the Regular Session on December 27, 2016; the attached list of Claims; the Liquor License Renewal for Red's Alehouse - Ownership change; t the Liquor License Application for Sugapeach, Special Class C Liquor License with Sunday sales endorsement; the Liquor License Application for Hoosier Bay Chapter of Delta Water Fowl, Special Class C Liquor License; January 27, 2017 Event; Change Order Number 9 for the Wastewater Treatment Plant Project to Tricon Construction Group in the amount of \$38,110.05; Pay Request Number 16 for the Wastewater Treatment Plant Project to Tricon Construction Group in the amount of \$301,521.89; Pay Request Number 5 for the Sponsored Water Quality Project to Metro Pavers in the amount of \$14,823.80; Pay Request Number 1 for the Well Improvement Project to Gingerich Well & Pump Service in the amount of \$291,350.75; and Pay Request Number 10 for the Penn Street ICAAP to Metro Pavers in the amount of \$3,880.64. After discussion, the vote was all ayes. Consent Agenda approved.

Public Comment

No public comment was offered.

City Planner Report

City Planner Wheatley reported on the Assessed Values report for the City. Council discussed the report with Wheatley. Councilor Pollock requested a comparative against other cities in Johnson County.

Wayson arrived at 6:32 p.m.

City Engineer Report

City Engineer Trom reported that the Forevergreen Road utilities project is progressing. Staff participated in a conference call with IDOT. The preliminary layout has started with identifying easement needs. IDOT is planning on a timeframe for bids in the fall of 2018. The water system project is in winter shutdown. The wells project contractor will be pump testing the Silurian well in the next month. Drilling will start on the Jordan well will be starting in the next week. The contractor has met all of the noise requirements, but has added more noise baffles to totally enclose the work site. The third bid package is pretty complete with plans out for bid soon. The wastewater treatment plant is about 84% complete with construction. The public hearing for Phase 2 of the North Liberty Road project is tonight with bids due on Monday. The final plans for the Penn Street Project have been submitted to IODT with a February 14 public hearing and February 21 letting in Ames. The project should be ready to award on February 28. The water storage/brine building is close to 100% complete design. The construction contract should be awarded sometime in the end of March. Council discussed the report with Trom.

Assistant City Administrator Report

Assistant City Administrator Mulcahey reported that she and Heiar are working diligently on the budget. The FY 2016 audit report is on tonight's agenda.

City Administrator Report

City Administrator Heiar reported that he met with the City's health insurance broker. Rates are going up 4.56%, below the trend of 10% Heiar updated Council on the Crisis Intervention Training Program. The budget work session is next Tuesday, January 17 at 5:30 p.m. He updated Council on the Fire Department report.

Mayor Pro Tem Report

Mayor Pro Tem Donahue reported that he and Councilor Wayson attended a lunch and learn on the state of emergency operations at the National Guard Armory this past Friday. Donahue requested a volunteer to attend the January MPO meeting. The City of North Liberty app has been temporarily discontinued due to issues with the vendor. Staff is examining other options.

FY 2016 Audit Report

Steve Kuhl; Winkel, Parker & Foster CPA, PC.; presented the audit results for FY 2016. Council discussed the audit with Kuhl.

Wayson moved, Hoffman seconded to approve Resolution Number 2017-01, A Resolution accepting the Audit Report for Fiscal Year 2016 as completed by Winkel, Parker & Foster CPA, PC. The vote was: ayes – Donahue, Hoffman, Sayre, Pollock, Wayson; nays – none. Motion carried.

O'Reilly's Auto Parts Site Plan

Wheatley presented the updated O'Reilly's Auto Parts Site Plan.

Pollock moved, Sayre seconded to remove the O'Reilly's Auto Parts Site Plan from the table. The vote was: ayes – Sayre, Wayson, Pollock, Donahue, Hoffman; nays – none. Motion carried.

Council discussed the application. Hoffman moved, Wayson seconded to approve Resolution Number 2017-02, A Resolution approving the Development Site Plan for Lot A, Wallace First

Subdivision, North Liberty, Iowa. After discussion, the vote was: ayes – Pollock, Wayson, Donahue, Sayre, Hoffman; nays – none. Motion carried.

Ogden Agreement

Heiar presented information relating to the agreement. Council discussed the agreement.

Hoffman moved, Sayre seconded to approve Resolution Number 2017-03, A Resolution approving the Agreement between Larry H. Ogden and Mary Jo Ogden and the City of North Liberty, Johnson County, Iowa. After discussion, the vote was: ayes – Donahue, Sayre, Pollock, Hoffman, Wayson; nays – none. Motion carried.

North Liberty Road Improvements Project

At 7:08 p.m., Mayor Pro Tem Donahue opened the public hearing regarding plans and specifications, form of contract and estimate of costs for the North Liberty Road Improvements Project. No oral or written comments were received. The public hearing was closed.

Wayson moved, Pollock seconded to approve Resolution Number 2017-04, A Resolution approving and confirming plans, specifications, form of contract and estimate of cost for the North Liberty Road Improvements Project. After discussion, the vote was: ayes – Pollock, Wayson, Hoffman, Donahue, Sayre; nays – none. Motion carried.

Telecommunications Commission Ordinance

Pollock moved, Hoffman seconded to approve the third consideration and adoption of Ordinance Number 2016-18, An Ordinance amending Chapter 25, “Telecommunications Commission” of the North Liberty Code of Ordinances by repealing current Chapter 25 and adopting new Chapter 25, “Communications Advisory Commission.” The vote was: ayes – Wayson, Donahue, Sayre, Pollock, Hoffman; nays –none. Motion carried.

Mayoral Vacancy

Council discussed the Mayoral vacancy. Sayre suggested taking no action tonight and review at the next meeting after budget work session on January 24 agenda. The consensus was to review this at the January 24 meeting.

Old Business

No old business was presented.

New Business

Councilor Hoffman will be attending the CBJ Economic Forecast lunch. Councilor Wayson reported that NLFD had busiest month ever.

Adjournment

At 7:19 p.m., Mayor Pro Tem Donahue adjourned the meeting.

CITY OF NORTH LIBERTY

By: _____
Terry L. Donahue, Mayor Pro Tem

Attest:

Tracey Mulcahey, City Clerk



Minutes

North Liberty City Council
January 17, 2017
Special Work Session

Call to order

Mayor Pro Tem Terry Donahue called the January 17, 2017 Special Session of the North Liberty City Council to order at 5:30 p.m. Councilors present: Terry Donahue, Chris Hoffman, Annie Pollock, Jim Sayre, and Brian Wayson.

Others present: Ryan Heiar, Tracey Mulcahey, Diane Venenga, Bill Schmooke Tom Palmer, Shelly Simpson, Jennie Garner, Guy Goldsmith, Scott Peterson, Dean Wheatley, Nick Bergus, Deb Hilton, Michael Pentecost, Greg Metternich, Dave Ramsey, Megan Benischek and other interested parties.

Approval of the Agenda

Pollock moved, Hoffman seconded to approve the agenda. The vote was all ayes. Agenda approved.

Budget Presentation - FY 2018

Heiar opened the discussion regarding the Fiscal Year 2018 Budget.

General Fund

The proposed Community and Economic Development budget was presented. Council discussed the Communications intern position, website upgrade, mobile communication hardware, plotter upgrade, economic development budget, specifics on what they are using the funds for.

Heiar presented the Public Safety budget proposal. Council discussed the proposed budgets with staff of the Police Department, Fire Department, Building Department, and Emergency Management.

Heiar presented information regarding the Public Works budget proposal. Council discussed the budget proposal with staff.

The proposed Culture and Recreation budget was presented. Council discussed the Library budget, the Parks budget, the Recreation budget, the Community Center budget, the Aquatic Center budget and the Cemetery budget with staff.

Heiar reported on the General Government budget proposal. Council discussed the proposed budget with staff.

General Fund Revenues for Fiscal Year 2018 were presented. Council discussed the proposed General Fund revenue budget.

The Road Use Tax Budget proposal was presented. Council discussed the proposed budget with staff.

Heiar presented the Water Budget proposal for FY 18. Council discussed the proposed budget with staff.

The Wastewater Budget proposal was presented. The proposed budget was discussed with staff.

Heiar presented the Storm Water Budget. Council discussed storm water budget and fees.

The Hotel/Motel Budget was presented and discussed.

The next meeting date will be January 31, 6:30 p.m. There will be a budget discussion item on Tuesday's agenda with discussion, if time allows.

Adjourn

At 8:10 p.m., Mayor Pro Tem Donahue adjourned the meeting.

CITY OF NORTH LIBERTY

By: _____
Terry L. Donahue, Mayor Pro Tem

Attest:

Tracey Mulcahey, City Clerk

	MONTH-TO-DATE BALANCE	YEAR-TO-DATE BALANCE
010-GENERAL FUND	2,062,156.58	6,919,220.61
011-FIRE EQUIPMENT CAPITA	0.00	0.00
012-LIBRARY CAPITAL FUND	1,178.50	10,963.45
013-RECREATION CAPITAL FU	0.00	574.00
014-POLICE CAPITAL FUND	1,830.00	10,713.52
015-TRANSPORTATION IMPACT	0.00	764,894.08
016-STORMWATER IMPACT FEE	0.00	0.00
017-TREE PROGRAM	0.00	0.00
018-PARK CAPITAL FUND	0.00	1,604,321.03
019-YOUTH SPORTS SCHOLARS	1,080.83	6,783.72
020-EQUIPMENT REVOLVING	231.05	1,856.00
021-TELECOMMUNICATIONS EQ	0.00	0.00
022-LIBRARY TAG	0.00	0.00
023-LIBRARY ENDOWMENT	0.00	0.00
024-DRUG TASK FORCE	0.00	0.00
025-POLICE SEIZED FUNDS	0.00	0.00
060-ROAD USE TAX FUND	123,665.12	885,660.77
061-STREET CAPITAL PROJEC	0.00	0.00
062-IJOBS STREETS	0.00	0.00
090-TIF FUND	17,731.99	2,171,062.68
110-DEBT SERVICE FUND	8,601.01	537,560.78
210-TRUST AND AGENCY	12,614.30	720,360.70
280-CUSTOMER DEPOSITS	7,630.00	94,740.00
310-COMMUNITY CENTER II C	0.00	0.00
311-FRONT STREET RECONSTR	0.00	0.00
312-CHERRY STREET RECONST	0.00	0.00
313-TIF PROJECTS	0.00	0.00
314-ENTRYWAY DEVELOPMENT	0.00	0.00
315-HIGHWAY 965 IMPROVEME	0.00	283,799.87
316-COMMUNITY CENTER PHAS	0.00	0.00
317-TRAIL PROJECTS	0.00	0.00
318-EC DEVELOPMENT PROJEC	0.00	0.00
319-PENN STREET IMPROVEME	0.00	0.00
320-LIBERTY CENTER PROJEC	0.00	0.00
321-LAND/FACILITIES	0.00	0.00
322-LIBRARY BUILDING FUND	210.49	8,262.97
323-LIBERTY CENTRE BLUES/	0.00	0.00
324-RANSHAW HOUSE PROJECT	0.00	0.00
510-WATER FUND	279,018.53	1,686,339.41
511-WATER CAPITAL RESERVE	0.00	82,496.00
512-WATER SINKING FUND	77,057.08	462,342.48
513-WATER BOND RESERVE	0.00	0.00
514-WATER CAPITAL PROJECT	0.00	0.00
520-SEWER FUND	344,087.13	2,049,905.54
521-SEWER CAPITAL RESERVE	17,125.00	279,714.00
522-SEWER SINKING FUND	113,135.33	678,811.98
523-WASTEWATER TREATMENT	951,432.01	3,319,552.74
524-SEWER TRUNK AND I&I	0.00	0.00
525-SEWER DEBT SERVICE RE	0.00	0.00
530-STORMWATER MANAGEMENT	16,520.00	349,255.90
532-STORMWATER SINKING FU	0.00	0.00
GRAND TOTAL REVENUE	4,035,304.95	22,929,192.23

Applicant License Application (LC0041399)

Name of Applicant: <u>SAN JUAN INC</u>		
Name of Business (DBA): <u>EL CACTUS AUTHENTIC MEXICAN CUISINE</u>		
Address of Premises: <u>40 SUGAR CREEK LN #5</u>		
City <u>North Liberty</u>	County: <u>Johnson</u>	Zip: <u>52317</u>
Business	<u>(319) 665-2046</u>	
Mailing	<u>40 Sugar Creek Ln</u>	
City <u>North Liberty</u>	State <u>IA</u>	Zip: <u>52317</u>

Contact Person

Name Ivan Armendariz
Phone: (319) 499-8603 Email ivanarmendariz6012@gmail.com

Classification Class C Liquor License (LC) (Commercial)

Term:12 months

Effective Date: 01/20/2018

Expiration Date:

Privileges:

Class C Liquor License (LC) (Commercial)

Status of Business

BusinessType: <u>Privately Held Corporation</u>
Corporate ID Number: <u>488181</u> Federal Employer ID <u>47-1950157</u>

Ownership

Jose Miguel Huerta

First Name: Jose

Last Name: Miguel Huerta

City: Moline

State: Illinois

Zip: 61244

Position: President

% of Ownership: 100.00%

U.S. Citizen: No

Insurance Company Information

Insurance Company: <u>Auto Owners Insurance Company</u>	
Policy Effective Date: <u>01/20/2017</u>	Policy Expiration <u>01/20/2018</u>
Bond Effective	Dram Cancel Date:
Outdoor Service Effective	Outdoor Service Expiration
Temp Transfer Effective	Temp Transfer Expiration Date:

Applicant License Application (LC0041399)

Name of Applicant: <u>SAN JUAN INC</u>		
Name of Business (DBA): <u>EL CACTUS AUTHENTIC MEXICAN CUISINE</u>		
Address of Premises: <u>40 SUGAR CREEK LN #5</u>		
City <u>North Liberty</u>	County: <u>Johnson</u>	Zip: <u>52317</u>
Business	<u>(319) 665-2046</u>	
Mailing	<u>40 Sugar Creek Ln</u>	
City <u>North Liberty</u>	State <u>IA</u>	Zip: <u>52317</u>

Contact Person

Name Ivan Armendariz
Phone: (319) 499-8603 Email ivanarmendariz6012@gmail.com

Classification Class C Liquor License (LC) (Commercial)

Term:12 months

Effective Date: 01/20/2017

Expiration Date: 01/19/2018

Privileges:

Class C Liquor License (LC) (Commercial)

Sunday Sales

Status of Business

BusinessType: <u>Privately Held Corporation</u>
Corporate ID Number: <u>488181</u> Federal Employer ID <u>47-1950157</u>

Ownership

ERICKA MARTINEZ

First Name: ERICKA **Last Name:** MARTINEZ
City: NORTH LIBERTY **State:** Iowa **Zip:** 52317
Position: PRESIDENT
% of Ownership: 100.00% **U.S. Citizen:** Yes

Insurance Company Information

Insurance Company: <u>Auto Owners Insurance Company</u>	
Policy Effective Date: <u>01/20/2017</u>	Policy Expiration <u>01/20/2018</u>
Bond Effective	Dram Cancel Date:
Outdoor Service Effective	Outdoor Service Expiration
Temp Transfer Effective	Temp Transfer Expiration Date:



North Liberty Police Department

5 E Cherry St • PO Box 77 • North Liberty, Iowa • 52317 • (319) 626-5724 / Fax: 5743

January 20, 2017

Liquor License Check

Business: El Cactus
40 Sugar Creek Lane Unit 5 & 6
North Liberty, IA 52317

Owner: Jose Miguel Huerta (DOB: 1969)

A record check of the above business and owner since 12/15/16 shows:

- Trespass calls – 2
- Civil disputes – 1
- Thefts – 1
- Fight/disturbances – 1

- NLPD recently arrested the manager on site for improper use of 911 communications.

North Liberty Police Department does not have any other documented contacts at this time and recommend their license be approved.

Record check completed by Chief Diane Venenga on 1/20/2017.



City of North Liberty
Inspection Report for Alcoholic Beverage Licensing
Chapter 15.04 of the Municipal Code

License Type Beer/Liquor Sunday Sales New/Renewal/Amended

Legal Name of Applicant: San Juan Inc.

Name of Business (DBA): El Cactus Authentic Mexican Cuisine

Address of Business: 40 Sugar Creek Lane # 5+6 - North Liberty, Ia

Contact Phone: Erika Martinez 665-2046 or 319-333-8852

emartinez02@gmail.com

Section 5.04.100 of the Municipal Code requires approval from the following City and County Departments

City of North Liberty Inspection Department:

The above mentioned property is located within a zoning district permitting the sale or consumption of alcoholic beverage.

[Signature]
Code Official

11-22-16
Date

An inspection was performed at the above referenced property to verify fire extinguisher maintenance program and exit requirements.

Designated Fire Inspector

Date

Johnson County Health Department:

The above mentioned food facility at the listed address is: (check one)

Is currently license in accordance with Iowa Food Code.

In the process of becoming licensed in accordance with the Iowa Food Code.

[Signature]
Johnson County Health Official

11/23/16
Date

City of North Liberty

Iworq Permit _____
Renewal letter 11/22/2016

License Expires 1/19/17
Official e-mail 11/22/2016

State License # LC0041399
Council Agenda date 12/13/2016



North Liberty Fire Dept (IA)
25 W Cherry St PO Box 77
North Liberty, IA 52317

Fire Dept Violation Notice

December 7, 2016

El Cactus
40 Sugar Creek LN, Suite #5 & 6
North Liberty, IA 52317

ORDER TO COMPLY: Since these conditions are contrary to law, you must correct them upon receipt of this notice. An inspection to determine compliance with this Notice will be conducted on or after 30 days from Dec 7, 2016.

If you fail to comply with this notice before the re-inspection date listed, you may be liable for the penalties & fees provided for by law for such violations.

Fire Inspection Fees:

- Initial Fire Inspection: No Charge
- 1st Re-Inspection: No Charge
- 2nd Re-Inspection: \$75.00
- Additional Re-Inspections: Municipal Infraction, Daily until Corrected.

Violations

703.1 Maintenance

Note Replace Sheetrock on wall in furnace room.



605.3 Working space and clearance

Note A working space of not less than 30 inches in width, 36 inches in depth and 78 inches in height shall be provided in front of electrical service equipment. Where the electrical service equipment is wider than 30 inches the working space shall not be less than the width of the equipment. No storage of any materials shall be located within the designated working space.



Violations

605.4.3 Installation

Note Relocatable power tap cords shall not extend through walls, ceilings, floors, under doors or floor coverings, or be subject to environmental or physical damage. Must be plugged directly into an outlet. Must be placed on the floor or secured to the wall.

-- surge protector next to tappers has exposed wiring. Needs to be replaced and mounted.



605.6 Unapproved conditions

Note Open junction boxes and open-wiring splices shall be prohibited. Approved covers shall be provided for all switch and electrical outlet boxes. No exposed wiring.

-- near restrooms, install cover for light switch.
-- outlet behind tv in bar is missing cover.

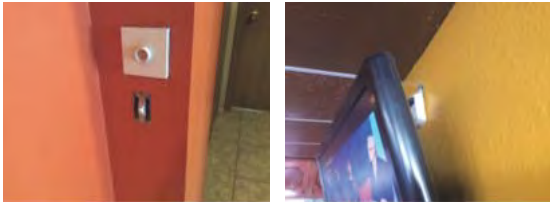

3003.5.3 Securing compressed gas containers

Note Securing compressed gas containers, cylinders and tanks. Compressed gas containers, cylinders and tanks shall be secured to prevent falling caused by contact, vibration or seismic activity. Tanks must be secured to the wall or non-movable object. Chain must be anchored on both sides of the tank.

-- secure all cylinders

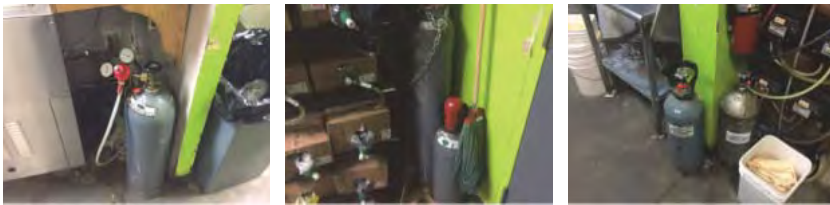

605.4 Multiplug adapters

Note Multiplug adapters, such as cube adapters, unfused plug strips or any other device not complying with NFPA 70 shall be prohibited.

-- north tv. Replace multi plug adapter with mounted surge protector.
-- tv in bar. Replace multi plug adapter with mounted surge protector



803.1 General

Note The provisions of this section shall limit the allowable flame spread and smoke development of interior wall and ceiling finishes and interior wall and ceiling trim in existing buildings based on location and occupancy classification.

Replace missing, broken and ceiling tiles with holes through restaurant.



313.1 General

Note Fire extinguishers shall be inspected either at a minimum of 30-day intervals by staff. Documentation of the 30 day inspection shall be recorded on the backside of the inspection tag (Date & Initials) or on a log book.

-- office, remove empty gas can.



609.3.3.1 TBL Cleaning Intervals

Note -- Current cooking operations is allowing cooking exhaust/smoke to vent throughout the restaurant which can be seen with a haze in the seating area. Move all cooking equipment under the hood at least 6" from the edge of the hood.

--Have mechanical contractor look at your exhaust fan to verify if it is operating correctly and sized correctly for your cooking operation. Have them provide a report to the building and fire department.

-- cheese melter (left of hood) was added without approval since last inspection. Is currently not installed correctly with exhaust and is using an extension cord. Submit application specifications to building depart for electrical, gas and mechanical review.



506.5.3 Exhaust fan mounting

Note Kitchen hood upblast exhaust fan is required to have hinges installed. Past deadline given to install hinges. Install in the next 45 days.

7.2.1.2 30 Day Inspection.

Note Fire extinguishers shall be inspected either at a minimum of 30-day intervals by staff. Documentation of the 30 day inspection shall be recorded on the backside of the inspection tag (Date & Initials) or on a log book.



906.7 Hangers and brackets

Note Hand-held portable fire extinguishers, not housed in cabinets, shall be installed on the hangers or brackets supplied. Hangers or brackets shall be securely anchored to the mounting surface in accordance with the manufacturer's installation instructions.

-- remount fire extinguisher near back door.



605.5 Extension cords

Note Extension cords and flexible cords shall not be a substitute for permanent wiring. Extension cords and flexible cords shall not be affixed to structures, extended through walls, ceilings or floors, or under doors or floor coverings, nor shall such cords be subject to environmental damage or physical impact. Extension cords shall be used only with portable appliances.

-- remove extension cord to Christmas tree. Can use surge protector.

-- under bar sink, surge protector is plugged into extension cord. Remove extension cord, plunge surge protector directly into outlet and mount to the wall.



Visit us at www.nfire.org

Complete code references can be found at: <http://www.nfire.org/permits.html>

Handwritten signature of Bryan Hardin.

HARDIN BRYAN HARDIN
Inspector

Handwritten signature of Ivan Ruiz.

Ivan ruiz

Applicant License Application (LE0002567)

Name of Applicant:	<u>Three Brothers Liquors LLC</u>		
Name of Business (DBA):	<u>Three Brothers Liquors</u>		
Address of Premises:	<u>585 Highway 965 Suite E</u>		
City	<u>North Liberty</u>	County:	<u>Johnson</u> Zip: <u>52317</u>
Business	<u>(319) 626-2046</u>		
Mailing	<u>585 Highway 965 Suite E</u>		
City	<u>North Liberty</u>	State	<u>IA</u> Zip: <u>52317</u>

Contact Person

Name	<u>Bhagwat & Yowa Acharya</u>		
Phone:	<u>(412) 251-7226</u>	Email	<u>ba_acharya22@yahoo.com</u>

Classification Class E Liquor License (LE)

Term:12 months

Effective Date: 03/01/2017

Expiration Date: 02/28/2018

Privileges:

- Class B Wine Permit
- Class C Beer Permit (Carryout Beer)
- Class E Liquor License (LE)
- Sunday Sales

Status of Business

BusinessType:	<u>Limited Liability Company</u>		
Corporate ID Number:	<u>493735</u>	Federal Employer ID	<u>47-2938154</u>

Ownership

Bhagwat Acharya

First Name: Bhagwat **Last Name:** Acharya
City: North Liberty **State:** Iowa **Zip:** 52317
Position: owner
% of Ownership: 50.00% **U.S. Citizen:** No

Yowa Acharya

First Name: Yowa **Last Name:** Acharya
City: North Liberty **State:** Iowa **Zip:** 52317
Position: owner
% of Ownership: 50.00% **U.S. Citizen:** No

Insurance Company Information

Insurance Company: Pekin Insurance Company

Policy Effective Date: 03/01/2017

Policy Expiration 01/01/1900

Bond Effective 2

Dram Cancel Date:

Outdoor Service Effective

Outdoor Service Expiration

Temp Transfer Effective

Temp Transfer Expiration Date:

Class B - Wine
Class C - Cansout Beer

City of North Liberty

Inspection Report for Alcoholic Beverage Licensing

Chapter 15.04 of the Municipal Code

License Type E Beer Liquor Sunday Sales ps New Renewal Amended

Legal Name of Applicant: Three Brothers LLC

Name of Business (DBA): Johneys Liquor Store

Address of Business: 585 Hwy 965 Suite E North Liberty Ia 52317

Contact Phone: 626-2046 Bhagwat or Yowa Acharya
ba_acharya.22@yahoo.com

Section 5.04.100 of the Municipal Code requires approval from the following City and County Departments

City of North Liberty Inspection Department:

The above mentioned property is located within a zoning district permitting the sale or consumption of alcoholic beverage.

[Signature]
Code Official

12/28/16
Date

An inspection was performed at the above referenced property to verify fire extinguisher maintenance program and exit requirements.

Designated Fire Inspector

Date

Johnson County Health Department:

The above mentioned food facility at the listed address is: (check one)

Is currently license in accordance with Iowa Food Code.

In the process of becoming licensed in accordance with the Iowa Food Code.

[Signature]
Johnson County Health Official

12/29/16
Date

City of North Liberty

Iworq Permit 6617

License Expires 2/28/17

State License # LE 0002567

Renewal letter emailed 12/28/2016

Official e-mail 12/28/16

Council Agenda date 1/24/2017

Rec ✓



North Liberty Police Department

5 E Cherry St • PO Box 77 • North Liberty, Iowa • 52317 • (319) 626-5724 / Fax: 5743

January 6, 2017

Liquor License Check

Business: Johncy's
585 S. Hwy 965 Suite E
North Liberty, IA 52317

Owner: Bhagwat Acharya (DOB: 1993)
Yowa Acharya (DOB: 1994)

A record check of the above business and owners shows no past incidents with the North Liberty Police Department that could affect the liquor license. This department does not have any concerns with the renewal of the liquor license.

I recommend the license be granted.

Sergeant Chris Shine





North Liberty Fire Dept (IA)
25 W Cherry St PO Box 77
North Liberty, IA 52317

Fire Dept Violation Notice

January 20, 2017

Johncy's Liquor Store
585 Highway 965 (City Limits), Suite #E
North Liberty, IA 52317

ORDER TO COMPLY: Since these conditions are contrary to law, you must correct them upon receipt of this notice. An inspection to determine compliance with this Notice will be conducted on or after 30 days from Jan 20, 2017.

If you fail to comply with this notice before the re-inspection date listed, you may be liable for the penalties & fees provided for by law for such violations.

Fire Inspection Fees:

- Initial Fire Inspection: No Charge
- 1st Re-Inspection: No Charge
- 2nd Re-Inspection: \$75.00
- Additional Re-Inspections: Municipal Infraction, Daily until Corrected.

Violations

605.4.3 Installation

Note Relocatable power tap cords shall not extend through walls, ceilings, floors, under doors or floor coverings, or be subject to environmental or physical damage. Must be plugged directly into an outlet. Must be placed on the floor or secured to the wall.

- Near front entrance.
- cord to coke refrigerator needs to be plugged directly into an electrical outlet.

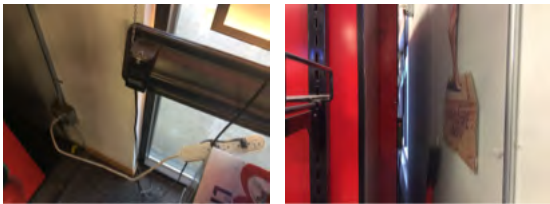

Visit us at www.nlfire.org
Complete code references can be found at: <http://www.nlfire.org/permits.html>



HARDIN BRYAN HARDIN
Inspector



Yowa acharya

Applicant License Application (LE0002690)

Name of Applicant:	<u>The Station LLC</u>		
Name of Business (DBA):	<u>The Station II</u>		
Address of Premises:	<u>620 Meade Dr</u>		
City	<u>North Liberty</u>	County:	<u>Johnson</u> Zip: <u>52317</u>
Business	<u>(319) 665-8516</u>		
Mailing	<u>955 236th St</u>		
City	<u>North Liberty</u>	State	<u>IA</u> Zip: <u>52317</u>

Contact Person

Name	<u>Melissa Hodapp</u>		
Phone:	<u>(319) 929-4520</u>	Email	<u>stationllc@gmail.com</u>

Classification Class E Liquor License (LE)

Term:12 months

Effective Date: 01/29/2017

Expiration Date: 01/28/2018

Privileges:

- Class B Wine Permit
- Class C Beer Permit (Carryout Beer)
- Class E Liquor License (LE)
- Fills and Sells Growlers
- Sunday Sales

Status of Business

BusinessType:	<u>Limited Liability Company</u>		
Corporate ID Number:	<u>435346</u>	Federal Employer ID	<u>800849276</u>

Ownership

Melissa Hodapp

First Name: Melissa **Last Name:** Hodapp
City: Iowa City **State:** Iowa **Zip:** 52240
Position: Owner
% of Ownership: 50.00% **U.S. Citizen:** Yes

Cory Hodapp

First Name: Cory **Last Name:** Hodapp
City: Iowa City **State:** Iowa **Zip:** 52240
Position: Owner
% of Ownership: 50.00% **U.S. Citizen:** Yes

Insurance Company Information

Insurance Company:	<u>Western Surety Company</u>		
Policy Effective Date:	<u>01/29/2017</u>	Policy Expiration	<u>01/01/1900</u>
Bond Effective	<u>2</u>	Dram Cancel Date:	
Outdoor Service Effective		Outdoor Service Expiration	
Temp Transfer Effective		Temp Transfer Expiration Date:	

City of North Liberty

Inspection Report for Alcoholic Beverage Licensing

Chapter 15.04 of the Municipal Code

Class B - Wine

Class C - Carryout Beer

License Type E Beer Liquor Sunday Sales yes New Renewal Amended

Legal Name of Applicant: The Station LLC

Name of Business (DBA): The Station II

Address of Business: 620 Meade Drive N. Liberty Ia. 52317

Contact Phone: Melissa Hodapp (319) 929-4520
stationllc@gmail.com

Section 5.04.100 of the Municipal Code requires approval from the following City and County Departments

City of North Liberty Inspection Department:

The above mentioned property is located within a zoning district permitting the sale or consumption of alcoholic beverage

[Signature]
Code Official

12-1-16
Date

An inspection was performed at the above referenced property to verify fire extinguisher maintenance program and exit requirements.

Designated Fire Inspector

Date

Johnson County Health Department:

The above mentioned food facility at the listed address is; (check one)

Is currently license in accordance with Iowa Food Code.

In the process of becoming licensed in accordance with the Iowa Food Code.

[Signature]
Johnson County Health Official

12/2/16
Date

City of North Liberty

Iworq Permit 6564
Renewal letter 11/29/16

License Expires 1/28/17
Official e-mail 11/29/16

State License # LE0002690
Council Agenda date 1/10/2017

995- 236th St #3



North Liberty Police Department

5 E Cherry St•PO Box 77•North Liberty, Iowa•52317•(319) 626-5724/Fax: 5743

December 15, 2016

Liquor License Check

Business: The Station II
618 Meade Dr.
North Liberty, IA 52317

Owners: Cory J. Hodapp (DOB: 1977)
Melissa M. Hodapp (DOB: 1983)

The North Liberty Police department does not have any documented contacts for the above owners or the business related to their liquor license.

I recommend the license be granted.

This record check was conducted by Sergeant Chris Shine.



City of North Liberty

Inspection Report for Alcoholic Beverage Licensing

Chapter 15.04 of the Municipal Code

Class B - Wine

Class C - Carryout Beer

License Type E Beer Liquor Sunday Sales Yes New Renewal Amended

Legal Name of Applicant: The Station LLC

Name of Business (DBA): The Station II

Address of Business: 620 Meade Drive N. Liberty Ia. 52317

Contact Phone: Melissa Hodapp (319) 929-4520

stationllc@gmail.com

Section 5.04.100 of the Municipal Code requires approval from the following City and County Departments

City of North Liberty Inspection Department:

The above mentioned property is located within a zoning district permitting the sale or consumption of alcoholic beverage

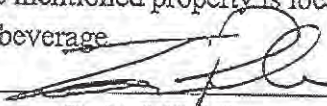

Code Official

12-1-16

Date

An inspection was performed at the above referenced property to verify fire extinguisher maintenance program and exit requirements.

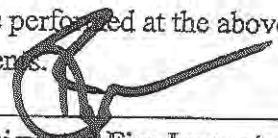

Designated Fire Inspector

12/28/16

Date

Johnson County Health Department:

The above mentioned food facility at the listed address is: (check one)

Is currently license in accordance with Iowa Food Code.

In the process of becoming licensed in accordance with the Iowa Food Code.

Johnson County Health Official

Date

City of North Liberty

Iworq Permit 6564

Renewal letter 11/29/16

License Expires 1/28/17

Official e-mail 11/29/16

State License # LE0002690

Council Agenda date 1/10/2017

995- 236th St #3



North Liberty Fire Dept (IA)
25 W Cherry St PO Box 77
North Liberty, IA 52317

Fire Dept Violation Notice

December 28, 2016

The Station II Convenience Store
620 Meade DR
North Liberty, IA 52317

An inspection of your facility on Dec 28, 2016 revealed no noticeable violations.

Visit us at www.nlfire.org
Complete code references can be found at: <http://www.nlfire.org/permits.html>

A handwritten signature in black ink, appearing to be "H. Hardin", written over a horizontal line.

HARDIN BRYAN HARDIN
Inspector

A handwritten signature in black ink, appearing to be "Paul Stallman", written over a horizontal line.

Paul stallman



ENGINEERS JOINT CONTRACT DOCUMENTS COMMITTEE

Contractor's Application for Payment No.

3 revised

Table with application details including Application Period (12/31/2016), Application Date (12/29/2016), To (City of North Liberty), From (Portzen Construction, Inc.), Via (Engineer) (FOX Engineering), Project (Phase 1 Water System Improvements Division 1 - Water Treatment Plant), and various contract numbers.

COPY
Matt
Revised

Application For Payment
Change Order Summary

Table with columns: Number, Additions, Deductions. Includes rows for COR 1 and a TOTALS row showing a net change of \$24,780.00.

Summary table with 9 rows: 1. ORIGINAL CONTRACT PRICE (\$13,449,000.00), 2. Net change by Change Orders (\$24,780.00), 3. Current Contract Price (\$13,473,780.00), 4. TOTAL COMPLETED AND STORED TO DATE (\$849,144.11), 5. RETAINAGE (a. 5% X 688,478.87 Work Completed \$34,423.94; b. 5% X 160,665.24 Stored Material \$8033.26; c. Total Retainage \$42,457.20), 6. AMOUNT ELIGIBLE TO DATE (\$806,686.91), 7. LESS PREVIOUS PAYMENTS (\$626,015.00), 8. AMOUNT DUE THIS APPLICATION (\$180,671.91), 9. BALANCE TO FINISH, PLUS RETAINAGE (\$12,667,093.09).

Contractor's Certification

The undersigned Contractor certifies, to the best of its knowledge, the following:
(1) All previous progress payments received from Owner on account of Work done under the Contract have been applied on account to discharge Contractor's legitimate obligations incurred in connection with the Work covered by prior Applications for Payment;
(2) Title to all Work, materials and equipment incorporated in said Work, or otherwise listed in or covered by this Application for Payment, will pass to Owner at time of payment free and clear of all Liens, security interests, and encumbrances (except such as are covered by a bond acceptable to Owner indemnifying Owner against any such Liens, security interest, or encumbrances); and
(3) All the Work covered by this Application for Payment is in accordance with the Contract Documents and is not defective.

Contractor Signature: Jayme Kluesner, Controller
Date: 12/30/2016

Payment of: \$180,671.91
is recommended by: Steven J. Hozer (Engineer) 1-17-17 (Date)
Payment of: \$
is approved by: (Owner) (Date)
Approved by: Funding or Financing Entity (if applicable) (Date)

Date of Issuance: January 17, 2017	Effective Date: June 25, 2015
Owner: City of North Liberty, Iowa	Owner's Contract No.: N/A
Contractor: Tricon Construction Group, Dubuque, IA	Contractor's Project No.: 15-012-1A
Engineer: FOX Engineering	Engineer's Project No.: 2489-11A.660
Project: Phase II WWTP Improvements	Contract Name:

The Contract is modified as follows upon execution of this Change Order:

Description:

- Item 1** Change Proposal Request (CPR) No. 028 (Contractor's Change Order Request (COR) No. 56): Install a backup pressure transmitter and controls for shutting down the permeate pumps when a high water level is reached in the backpulse tank. This would help ensure that the backpulse tank does not overflow into the pump room if the existing pressure transmitter malfunctions. **Add \$18,852.04.**
- Item 2** CPR No. 030 (COR No. 57): Replace the installed polymer drum scale with a tote scale in the Dewatering Building. The plant decided to feed polymer from chemical totes instead of drums, so the replacement is necessary to provide the correct size and weight capacity. **Add \$5,822.46.**
- Item 3** COR No. 52: Reroute existing air compressor and air dryer control wiring in the Secondary Treatment Building from the Fine Screen Room, which is a rated space. The existing control wiring was found in the same raceway system as other instrumentation wiring scheduled for removal. **Add \$2,912.75**

Attachments: CPR No. 028 (Contractor COR 56), CPR No. 030 (COR 57), COR 52

CHANGE IN CONTRACT PRICE	CHANGE IN CONTRACT TIMES <i>[note changes in Milestones if applicable]</i>
Original Contract Price: <u>\$ 15,621,000.00</u>	Original Contract Times: Substantial Completion: <u>June 30, 2017</u> Ready for Final Payment: <u>August 30, 2017</u>
[Increase] [Decrease] from previously approved Change Orders No. <u>1</u> to No. <u>9</u> : <u>\$ 155,749.55</u>	[Increase] [Decrease] from previously approved Change Orders No. <u>1</u> to No. <u>9</u> : Substantial Completion: <u>14 days</u> Ready for Final Payment: <u>14 days</u>
Contract Price prior to this Change Order: <u>\$ 15,776,749.55</u>	Contract Times prior to this Change Order: Substantial Completion: <u>July 14, 2017</u> Ready for Final Payment: <u>September 13, 2017</u>
[Increase] [Decrease] of this Change Order: <u>\$27,587.25</u>	[Increase] [Decrease] of this Change Order: Substantial Completion: <u>0 days</u> Ready for Final Payment: <u>0 days</u>
Contract Price incorporating this Change Order: <u>\$ 15,804,336.80</u>	Contract Times with all approved Change Orders: Substantial Completion: <u>July 14, 2017</u> Ready for Final Payment: <u>September 13, 2017</u>

<p>RECOMMENDED:</p> <p>By: <u>Jennifer Readdy</u> Engineer (if required)</p> <p>Title: <u>Project Engineer</u></p> <p>Date: <u>1-17-17</u></p>	<p>ACCEPTED:</p> <p>By: _____ Owner (Authorized Signature)</p> <p>Title: _____</p> <p>Date: _____</p>	<p>ACCEPTED:</p> <p>By: <u>[Signature]</u> Contractor (Authorized Signature)</p> <p>Title: <u>owner</u></p> <p>Date: <u>1.17.17</u></p>
--	---	---

Approved by Funding Agency (if applicable)

By: _____

Date:

Title: _____

Mayor Report

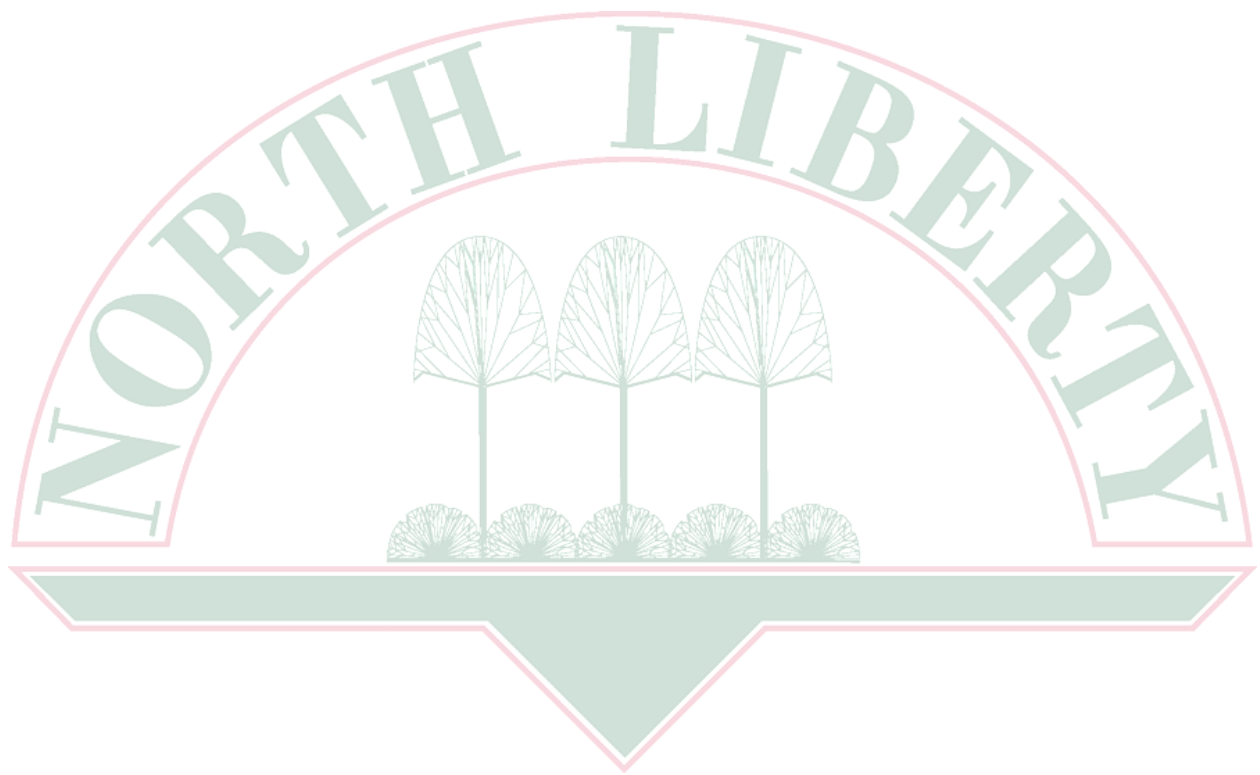



STATEMENT OF SUPPORT FOR THE GUARD AND RESERVE



City of North Liberty

We recognize the Guard and Reserve are essential to the strength of our Nation and the well-being of our communities.

In the highest American tradition, the patriotic men and women of the Guard and Reserve serve voluntarily in an honorable and vital profession. They train to respond to their community and their country in time of need. They deserve the support of every segment of our society.

If these volunteer forces are to continue to serve our Nation, increased public understanding is required of the essential role of the Guard and Reserve in preserving our national security.

Therefore, we join other employers in pledging that:

- We fully recognize, honor and comply with the Uniformed Services Employment and Reemployment Rights Act (USERRA).
- We will provide our managers and supervisors with the tools they need to effectively manage those employees who serve in the Guard and Reserve.
- We appreciate the values, leadership and unique skills Service members bring to the workforce and will encourage opportunities to employ Guardsmen, Reservists, transitioning Service members and Veterans.
- We will continually recognize and support our country's Service members and their families in peace, in crisis, and in war.

Employer

Paul E. Mock
National Chair, ESGR

Ash Carter
Secretary of Defense

Date



Phase I Water System Improvements, Division II – Water Mains

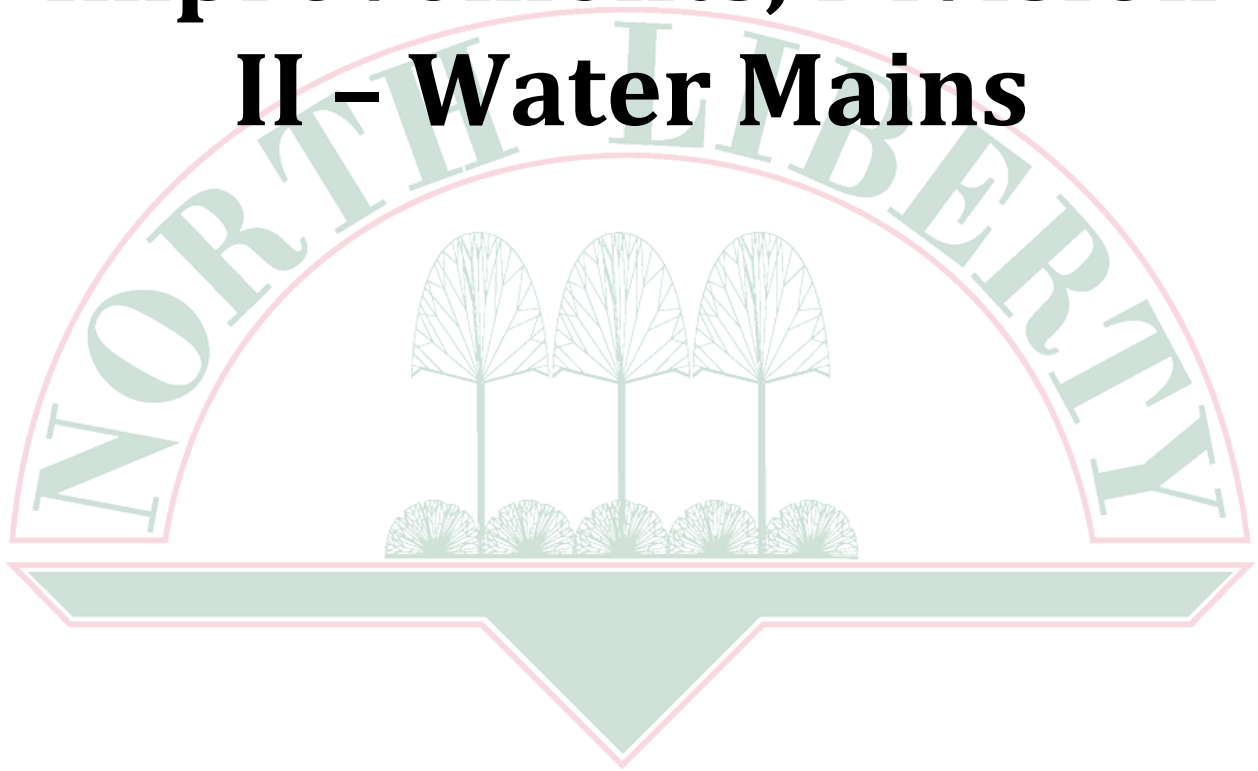

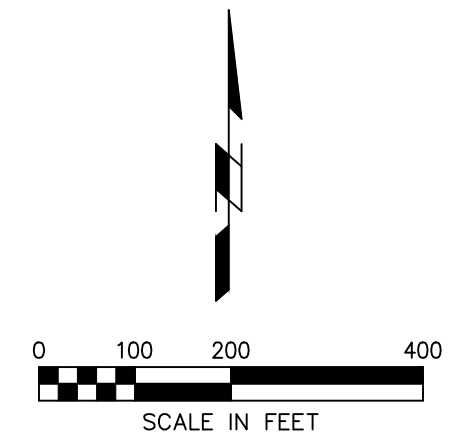
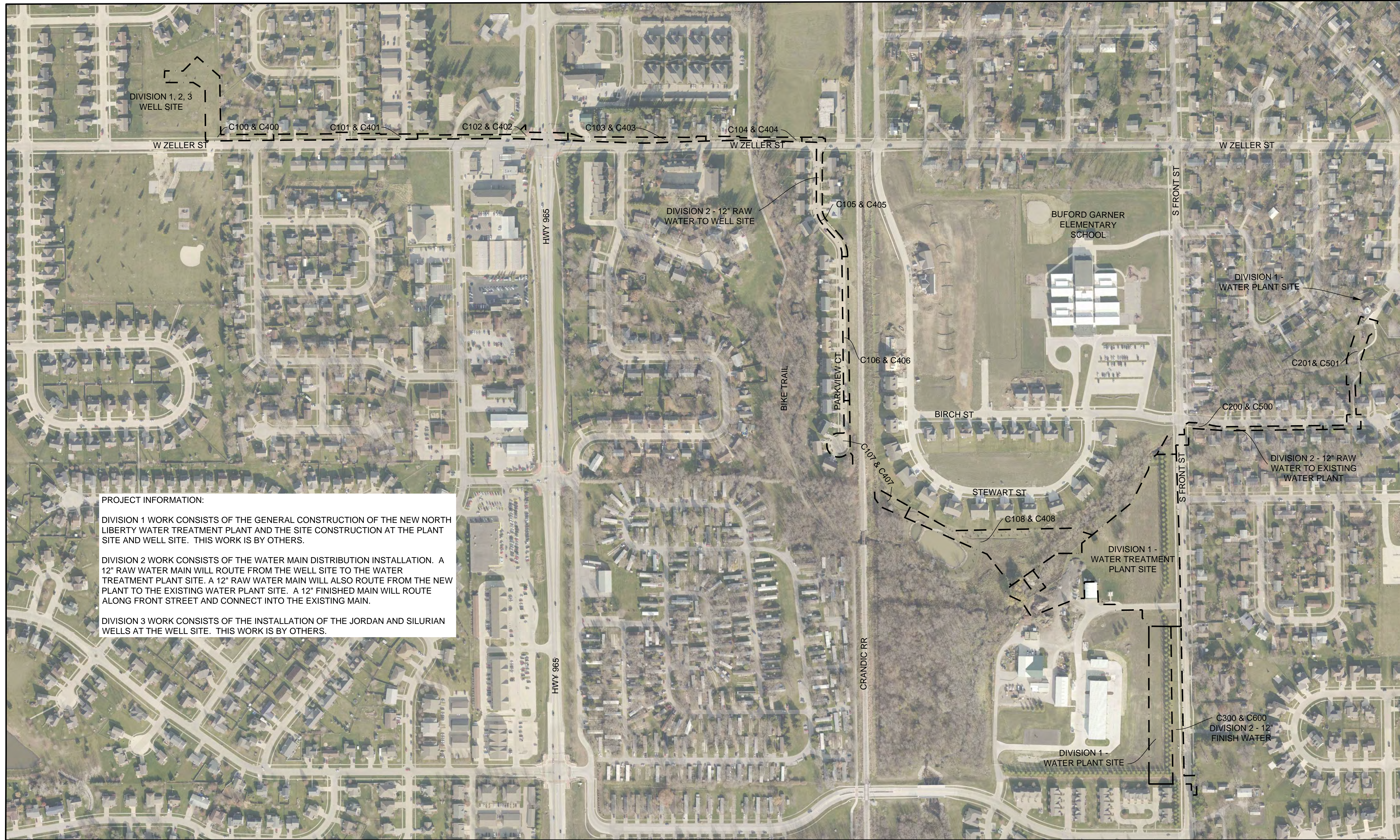

PROJECT INFORMATION:

DIVISION 1 WORK CONSISTS OF THE GENERAL CONSTRUCTION OF THE NEW NORTH LIBERTY WATER TREATMENT PLANT AND THE SITE CONSTRUCTION AT THE PLANT SITE AND WELL SITE. THIS WORK IS BY OTHERS.

DIVISION 2 WORK CONSISTS OF THE WATER MAIN DISTRIBUTION INSTALLATION. A 12" RAW WATER MAIN WILL ROUTE FROM THE WELL SITE TO THE WATER TREATMENT PLANT SITE. A 12" RAW WATER MAIN WILL ALSO ROUTE FROM THE NEW PLANT TO THE EXISTING WATER PLANT SITE. A 12" FINISHED MAIN WILL ROUTE ALONG FRONT STREET AND CONNECT INTO THE EXISTING MAIN.

DIVISION 3 WORK CONSISTS OF THE INSTALLATION OF THE JORDAN AND SILURIAN WELLS AT THE WELL SITE. THIS WORK IS BY OTHERS.

REVISION	DATE	BY

SHIVEHATTERY
 ARCHITECTURE + ENGINEERING
 2830 Northgate Dr. | Iowa City, IA 52245
 319.354.3040 | fax.319.354.6921 | www.shivehattery.com
 Iowa | Illinois | Indiana | Missouri

FOX Engineering Associates, Inc.
 414 South 17th Street, Suite 107
 Ames, Iowa 50010
 Phone: (515)233-0000
 Fax: (515)233-0103

FOX engineering

OVERALL MAP - RAW WATER MAIN AND FINISH WATER SUPPLY WATER SYSTEM IMPROVEMENTS
 CITY OF NORTH LIBERTY
 NORTH LIBERTY, IOWA

PROJECT NO.
3373-15A

SHEET
C001

LAST UPDATE: 01/16/17

Resolution No. 2017-05

RESOLUTION FINALLY APPROVING AND CONFIRMING PLANS, SPECIFICATIONS, FORM OF CONTRACT AND ESTIMATE OF COST FOR THE PHASE I WATER SYSTEM IMPROVEMENTS DIVISION II – WATER MAINS

WHEREAS, the City Council of the City of North Liberty, Iowa, has heretofore given preliminary approval to the plans, specifications, form of contract and estimate of cost (the “Contract Documents”) for the proposed Phase I Water System Improvements Project Division II – Water Mains (the “Project”), as described in the notice of hearing on the Contract Documents for the Project and the taking of bids therefor; and

WHEREAS, a hearing has been held on the Contract Documents on January 24, 2017;

NOW, THEREFORE, BE IT RESOLVED by the City Council of the City of North Liberty, Iowa, as follows:

Section 1. The City Council hereby delegates to the City Clerk and/or the Project Engineer the duty of receiving bids for the Project until 10:00 o’clock a.m. on February 7, 2017 at the City Administration Building in the City. At such time and place the City Clerk and/or the Project Engineer open such bids received and announce the results thereof. The City Council will consider bids received at the City Council meeting to be held on February 14, 2017 at 6:30 p.m. at City Council Chambers in the City.

Section 2. The City Clerk is hereby authorized and directed to give notice of the hearing and taking of bids by publication as required by law, which publication shall be made not less than 4 and not more than 45 days prior to the date for receipt of bids and not less than 4 and not more than 20 days prior to the date of the said hearing. The said notice shall be in the form substantially as attached to this resolution.

Section 3. “Pursuant to Section 1.150-2 of the Income Tax Regulations (the “Regulations”) of the Internal Revenue Service, the City declares (a) that it intends to undertake the Project, (b) that other than (i) expenditures to be paid or reimbursed from sources other than the issuance of bonds, notes or other obligations (the “Bonds”), or (ii) expenditures made not earlier than 60 days prior to the date of this Resolution or a previous intent resolution of the City, or (iii) expenditures amounting to the lesser of \$100,000 or 5% of the proceeds of the Bonds, or (iv) expenditures constituting preliminary expenditures as defined in Section 1.150-2(f)(2) of the Regulations, no expenditures for the Project have heretofore been made by the City and no expenditures will be made by the City until after the date of this Resolution or a prior intent resolution of the City, and (c) that the City reasonably expects to reimburse the expenditures made for costs of the City out of the proceeds of the Bonds. This declaration is a declaration of official intent adopted pursuant to Section 1.150-2 of the Regulations.

Section 4. The Contract Documents referred to in the preamble hereof are hereby finally approved, and the prior action of the City Council giving preliminary approval is hereby finally confirmed, and the Project, as provided for in the Contract Documents, is necessary and desirable.

Section 5. All resolutions or parts of resolutions in conflict herewith are hereby repealed to the extent of such conflict.

APPROVED AND ADOPTED this 24th day of January, 2017.

CITY OF NORTH LIBERTY:

ATTEST:

TERRY L. DONAHUE, MAYOR PRO TEM

TRACEY MULCAHEY, CITY CLERK

North Liberty Road Project



January 18, 2017

City of North Liberty
ATTN: Mr. Ryan Heiar, City Administrator
P.O. Box 77
North Liberty, Iowa 52317

RE: North Liberty Road Improvements Project

Dear Mr. Heiar:

On January 16, 2017 at 11:00 am in the North Liberty City Administration building six bids were received and opened for the above-referenced project.

The low bid was received from Metro Pavers, Inc, Iowa in the amount of \$2,250,623.32. The engineer's estimate was \$2,845,320.00.

Subject to submitting acceptable bonds, insurance and the Agreement, we recommend award of contract to Metro Pavers, Inc. based upon their lowest responsible, responsive bid. Upon City Council approval of this award we will proceed with issuing the Notice of Award and begin administration of the construction contract.

Please contact our office if you have questions.

Sincerely,

SHIVE-HATTERY, INC.



Eric Munchel, PE

JDB/bad

Enc. Bid Tabulation

Copy: Tracey Mulcahey, Assistant City Administrator
Michael Pentecost, Streets Superintendent
Scott Peterson, City Attorney
Kevin Trom, S-H



SHIVE-HATTERY, INC.
 2839 Northgate Drive
 Iowa City, Iowa 52245-9568
 (319) 354-3040 FAX (319) 354-6921

TABULATION OF BIDS

Client: City of North Liberty
 Project Name: North Liberty Road Improvements
 S-H Project #: 1161620

Bid Date: January 16, 2017, 11:00 A.M.
 Location: City Admin. Bldg., North Liberty, IA
 Page No.: 1 of 2

NAME AND ADDRESS OF BIDDER			Metro Pavers, Inc. PO Box 2508 Iowa City, Iowa 52244	Streb Construction PO Box 5065 Coralville, Iowa 52241	BWC Excavating, LC 1303 Hickory Hollow Rd. Solon, Iowa 52333	Horsfield Construction, Inc. 505 East Main Street Epworth, Iowa 52045					
Addenda Nos. 1 - 2			Yes	Yes	Yes	Yes					
Bid Security			Yes	Yes	Yes	Yes					
Bidder Status Form			Yes	No	Yes	Yes					
ITEM	DESCRIPTION	QUANTITY	UNIT PRICE	EXTENDED PRICE	UNIT PRICE	EXTENDED PRICE	UNIT PRICE	EXTENDED PRICE	UNIT PRICE	EXTENDED PRICE	
1	Clearing and Grubbing	1,518.3	UNIT	\$16.25	\$24,672.38	\$16.25	\$24,672.38	\$75.00	\$113,872.50	\$11.80	\$17,915.94
2	Excavation, Class 10, Roadway and Borrow	83,331	CY	\$2.33	\$194,161.23	\$2.33	\$194,161.23	\$4.75	\$395,822.25	\$3.03	\$252,492.93
3	Topsoil, Strip, Salvage and Spread	20,127	CY	\$2.88	\$57,965.76	\$2.88	\$57,965.76	\$6.00	\$120,762.00	\$1.40	\$28,177.80
4	Subgrade Stabilization	23,015	SY	\$8.39	\$193,095.85	\$8.40	\$193,326.00	\$2.50	\$57,537.50	\$5.85	\$134,637.75
5	Modified Subbase	4,240	CY	\$28.00	\$118,720.00	\$31.45	\$133,348.00	\$17.50	\$74,200.00	\$26.45	\$112,148.00
6	Shoulder Finishing, Earth	6.50	STA	\$260.00	\$1,690.00	\$260.00	\$1,690.00	\$1,000.00	\$6,500.00	\$200.00	\$1,300.00
7	Macadam Stone Base	455	TON	\$19.85	\$9,031.75	\$19.85	\$9,031.75	\$18.50	\$8,417.50	\$20.00	\$9,100.00
8	Relocation of Mail Boxes	9	EA	\$250.00	\$2,250.00	\$250.00	\$2,250.00	\$210.00	\$1,890.00	\$150.00	\$1,350.00
9	STD or Slip Form PCC Pavement, CL C, CL 3l Durability, 7 In.	115	SY	\$39.00	\$4,485.00	\$42.00	\$4,830.00	\$42.00	\$4,830.00	\$65.00	\$7,475.00
10	STD or Slip Form PCC Pavement, CL C, CL 3l Durability, 9 In.	19,420	SY	\$35.80	\$695,236.00	\$43.00	\$835,060.00	\$39.00	\$757,380.00	\$48.00	\$932,160.00
11	Surfacing, Driveway, Class A Crushed Stone	455	TON	\$21.15	\$9,623.25	\$21.15	\$9,623.25	\$17.50	\$7,962.50	\$14.25	\$6,483.75
12	Removal of Sign	4	EA	\$50.00	\$200.00	\$70.00	\$280.00	\$70.00	\$280.00	\$150.00	\$600.00
13	Removals, As Per Plan	1	LS	\$3,500.00	\$3,500.00	\$3,500.00	\$3,500.00	\$7,500.00	\$7,500.00	\$20,000.00	\$20,000.00
14	Aprons, Concrete, 15 In. Dia.	3	EA	\$650.00	\$1,950.00	\$650.00	\$1,950.00	\$1,700.00	\$5,100.00	\$1,350.00	\$4,050.00
15	Aprons, Concrete, 18 In. Dia.	6	EA	\$700.00	\$4,200.00	\$700.00	\$4,200.00	\$2,300.00	\$13,800.00	\$1,400.00	\$8,400.00
16	Aprons, Concrete, 24 In. Dia.	1	EA	\$825.00	\$825.00	\$825.00	\$825.00	\$2,700.00	\$2,700.00	\$2,000.00	\$2,000.00
17	Aprons, Concrete, 48 In. Dia.	1	EA	\$1,600.00	\$1,600.00	\$1,600.00	\$1,600.00	\$4,000.00	\$4,000.00	\$3,400.00	\$3,400.00
18	Aprons, Concrete, 54 In. Dia.	2	EA	\$1,700.00	\$3,400.00	\$1,700.00	\$3,400.00	\$4,500.00	\$9,000.00	\$3,500.00	\$7,000.00
19	Aprons, Concrete, 60 In. Dia.	2	EA	\$2,250.00	\$4,500.00	\$2,250.00	\$4,500.00	\$5,300.00	\$10,600.00	\$4,500.00	\$9,000.00
20	Apron, Low Clearance Concrete, Equivalent Diameter 24 In.	20	EA	\$800.00	\$16,000.00	\$800.00	\$16,000.00	\$2,300.00	\$46,000.00	\$1,600.00	\$32,000.00
21	Manhole, Storm Sewer, SW-401, 60 In.	2	EA	\$3,650.00	\$7,300.00	\$3,650.00	\$7,300.00	\$2,570.00	\$5,140.00	\$4,500.00	\$9,000.00
22	Manhole, Storm Sewer, SW-401, 108 In.	1	EA	\$16,200.00	\$16,200.00	\$16,200.00	\$16,200.00	\$15,750.00	\$15,750.00	\$16,500.00	\$16,500.00
23	Intake, SW-509	3	EA	\$3,800.00	\$11,400.00	\$3,800.00	\$11,400.00	\$4,100.00	\$12,300.00	\$3,500.00	\$10,500.00
24	Intake, SW-512, 24 In.	2	EA	\$1,600.00	\$3,200.00	\$1,600.00	\$3,200.00	\$1,200.00	\$2,400.00	\$1,600.00	\$3,200.00
25	Intake, SW-512, 36 In.	1	EA	\$5,000.00	\$5,000.00	\$5,000.00	\$5,000.00	\$5,300.00	\$5,300.00	\$3,700.00	\$3,700.00
26	Intake, SW-513 - 36"x48"	1	EA	\$3,400.00	\$3,400.00	\$3,400.00	\$3,400.00	\$4,200.00	\$4,200.00	\$3,000.00	\$3,000.00
27	Intake, SW-513 - 36"x42"	1	EA	\$3,400.00	\$3,400.00	\$3,400.00	\$3,400.00	\$4,800.00	\$4,800.00	\$3,000.00	\$3,000.00
28	Intake, SW-513 - 48"x48"	1	EA	\$3,800.00	\$3,800.00	\$3,800.00	\$3,800.00	\$5,200.00	\$5,200.00	\$3,000.00	\$3,000.00
29	Intake, SW-513 - 60"x72"	2	EA	\$4,400.00	\$8,800.00	\$4,400.00	\$8,800.00	\$5,700.00	\$11,400.00	\$3,500.00	\$7,000.00
30	Intake, SW-513 - 60"x84"	2	EA	\$5,400.00	\$10,800.00	\$5,400.00	\$10,800.00	\$6,850.00	\$13,700.00	\$4,000.00	\$8,000.00
31	Subdrain, Longitudinal, (Backslope) 6 In. Dia.	1,910	LF	\$9.00	\$17,190.00	\$9.00	\$17,190.00	\$4.50	\$8,595.00	\$12.00	\$22,920.00
32	Subdrain, Longitudinal, (Shoulder) 4 In. Dia.	200	LF	\$6.00	\$1,200.00	\$6.00	\$1,200.00	\$5.00	\$1,000.00	\$12.00	\$2,400.00
33	Subdrain Outlet, DR-303	4	EA	\$100.00	\$400.00	\$100.00	\$400.00	\$200.00	\$800.00	\$200.00	\$800.00
34	Subdrain Outlet, DR-304	4	EA	\$300.00	\$1,200.00	\$300.00	\$1,200.00	\$200.00	\$800.00	\$400.00	\$1,600.00
35	Special Pipe Connection- Type PC-1	3	EA	\$875.00	\$2,625.00	\$875.00	\$2,625.00	\$600.00	\$1,800.00	\$500.00	\$1,500.00
36	Subdrain Cleanout, 6 In., As Per Plan	5	EA	\$400.00	\$2,000.00	\$400.00	\$2,000.00	\$200.00	\$1,000.00	\$550.00	\$2,750.00
37	Storm Sewer Gravity Main, Trenched, RCP 2000D (CL III), 12 In.	17	LF	\$30.00	\$510.00	\$30.00	\$510.00	\$85.00	\$1,445.00	\$45.00	\$765.00
38	Storm Sewer Gravity Main, Trenched, RCP 2000D (CL III), 15 In.	268	LF	\$35.00	\$9,380.00	\$35.00	\$9,380.00	\$49.00	\$13,132.00	\$50.00	\$13,400.00
39	Storm Sewer Gravity Main, Trenched, RCP 2000D (CL III), 18 In.	390	LF	\$38.00	\$14,820.00	\$38.00	\$14,820.00	\$53.00	\$20,670.00	\$60.00	\$23,400.00
40	Storm Sewer Gravity Main, Trenched, RCP 2000D (CL III), 24 In.	180	LF	\$45.00	\$8,100.00	\$45.00	\$8,100.00	\$58.00	\$10,440.00	\$65.00	\$11,700.00
41	Storm Sewer Gravity Main, Trenched, RCP 2000D (CL III), 42 In.	26	LF	\$125.00	\$3,250.00	\$125.00	\$3,250.00	\$150.00	\$3,900.00	\$150.00	\$3,900.00
42	Storm Sewer Gravity Main, Trenched, RCP 2000D (CL III), 48 In.	78	LF	\$155.00	\$12,090.00	\$155.00	\$12,090.00	\$200.00	\$15,600.00	\$245.00	\$19,110.00
43	Storm Sewer Gravity Main, Trenched, RCP 2000D (CL III), 54 In.	146	LF	\$180.00	\$26,280.00	\$180.00	\$26,280.00	\$235.00	\$34,310.00	\$250.00	\$36,500.00
44	Storm Sewer Gravity Main, Trenched, RCP 2000D (CL III), 60 In.	227	LF	\$200.00	\$45,400.00	\$200.00	\$45,400.00	\$275.00	\$62,425.00	\$255.00	\$57,885.00
45	Storm Sewer Gravity Main, Trenched, 2000D Low Clearance Concrete Pipe, Equiv. Dia. 24 In.	241	LF	\$65.00	\$15,665.00	\$65.00	\$15,665.00	\$85.00	\$20,485.00	\$85.00	\$20,485.00
46	Remove Storm Sewer Pipe Less Than or Equal to 36 In.	373	LF	\$10.00	\$3,730.00	\$10.00	\$3,730.00	\$17.00	\$6,341.00	\$12.00	\$4,476.00
47	Remove Storm Sewer Pipe Greater Than 36 In.	243	LF	\$12.00	\$2,916.00	\$12.00	\$2,916.00	\$17.00	\$4,131.00	\$30.00	\$7,290.00
48	Remove and Reinstall Storm Sewer Pipe Less Than or Equal to 36 In.	27	LF	\$42.00	\$1,134.00	\$42.00	\$1,134.00	\$52.00	\$1,404.00	\$70.00	\$1,890.00
49	Revelment, Class E	1,225	TON	\$35.65	\$43,671.25	\$35.65	\$43,671.25	\$38.00	\$46,560.00	\$37.00	\$45,325.00
50	Erosion Stone	861	TON	\$24.95	\$21,481.95	\$24.95	\$21,481.95	\$33.00	\$28,413.00	\$22.10	\$19,028.10
51	Backfill for Retaining Wall	1,600	TON	\$6.38	\$10,208.00	\$0.01	\$16.00	\$18.00	\$28,800.00	\$5.00	\$8,000.00
52	Segmental Block Retaining Wall	2,680	SF	\$39.50	\$105,860.00	\$53.00	\$142,040.00	\$54.00	\$144,720.00	\$53.00	\$142,040.00
53	Removal of Pavement	169	SY	\$9.35	\$1,580.15	\$9.35	\$1,580.15	\$24.00	\$4,056.00	\$15.00	\$2,535.00
54	Driveway, P.C. Concrete, 6 In.	385	SY	\$35.50	\$13,667.50	\$40.00	\$15,400.00	\$45.00	\$17,325.00	\$55.00	\$21,175.00
55	Fence, Chain Link, 48 In. Height	318	LF	\$24.75	\$7,870.50	\$24.75	\$7,870.50	\$25.00	\$7,950.00	\$25.00	\$7,950.00
56	Fence, Field - Temporary	6,000	LF	\$3.75	\$22,500.00	\$3.75	\$22,500.00	\$4.00	\$24,000.00	\$4.00	\$24,000.00
57	Fence, Field	7,730	LF	\$7.95	\$61,453.50	\$7.95	\$61,453.50	\$8.00	\$61,840.00	\$8.00	\$61,840.00
58	Gate, Field Fence, 16 Ft.	8	EA	\$775.00	\$6,200.00	\$775.00	\$6,200.00	\$775.00	\$6,200.00	\$800.00	\$6,400.00
59	Removal of Fence, Field	7,900	LF	\$2.75	\$21,725.00	\$2.75	\$21,725.00	\$0.25	\$1,975.00	\$1.25	\$9,875.00
60	Remove and Reinstall Sign As Per Plan	10	EA	\$100.00	\$1,000.00	\$135.00	\$1,350.00	\$135.00	\$1,350.00	\$100.00	\$1,000.00
61	Perforated Square Steel Tube Posts	96	LF	\$10.00	\$960.00	\$9.75	\$936.00	\$10.00	\$960.00	\$10.00	\$960.00
62	Perforated Square Steel Tube Post Anchor, Break-Away Soil Installation	7	EA	\$100.00	\$700.00	\$175.00	\$1,225.00	\$175.00	\$1,225.00	\$100.00	\$700.00
63	Type A Signs, Sheet Aluminum	35	SF	\$20.00	\$700.00	\$17.25	\$603.75	\$25.00	\$875.00	\$20.00	\$700.00
64	Painted Pavement Markings, Durable	212	STA	\$65.00	\$13,780.00	\$69.50	\$14,734.00	\$70.00	\$14,840.00	\$65.00	\$13,780.00
65	Traffic Control	1	LS	\$5,650.00	\$5,650.00	\$6,000.00	\$6,000.00	\$10,000.00	\$10,000.00	\$5,650.00	\$5,650.00
66	Mobilization	1	LS	\$65,000.00	\$65,000.00	\$120,000.00	\$120,000.00	\$100,000.00	\$100,000.00	\$350,000.00	\$350,000.00
67	Temporary Access Drives	1	LS	\$10,500.00	\$10,500.00	\$10,500.00	\$10,500.00	\$2,500.00	\$2,500.00	\$7,500.00	\$7,500.00
68	Compost Filter Tube (8 In. Dia.) or Silt Fence	15,400	LF	\$1.50	\$23,100.00	\$1.50	\$23,100.00	\$1.75	\$26,950.00	\$1.50	\$23,100.00
69	Biodegradable Erosion Control Blanket	8,855	SQ	\$12.35	\$109,359.25	\$12.35	\$109,359.25	\$16.25	\$143,893.75	\$12.35	\$109,359.25
70	Hydraulic Seeding, Fertilizing and Mulching - Type 1	2.50	ACRE	\$3,600.00	\$9,000.00	\$3,600.00	\$9,000.00	\$4,300.00	\$10,750.00	\$3,600.00	\$9,000.00
71	Hydraulic Seeding, Fertilizing and Mulching - Type 2	17.80	ACRE	\$3,200.00	\$56,960.00	\$3,200.00	\$56,960.00	\$3,900.00	\$69,420.00	\$3,200.00	\$56,960.00
72	Stabilizing Crop - Seeding, Fertilizing and Mulching - Type 4	20	ACRE	\$450.00	\$9,000.00	\$450.00	\$9,000.00	\$1,600.00	\$32,000.00	\$450.00	\$9,000.00
73	Permeable Ditch Checks	4,200	LF	\$5.50	\$23,100.00	\$5.50	\$23,100.00	\$2.50	\$10,500.00	\$5.50	\$23,100.00
74	Removal of Compost Filter Tube, Silt Fence or Ditch Checks	19,600	LF	\$0.15	\$2,940.00	\$0.15	\$2,940.00	\$0.25	\$4,900.00	\$0.15	\$2,940.00
75	Maintenance of Compost Filter Tube, Silt Fence or Ditch Checks	19,600	LF	\$0.05	\$980.00	\$0.05	\$980.00	\$0.25	\$4,900.00	\$0.05	\$980.00
76	Mobilization, Erosion Control	15	EA	\$250.00	\$3,750.00	\$250.00	\$3,750.00	\$500.00	\$7,500.00	\$750.00	\$11,250.00
77	Temporary Sediment Control Basin	11	EA	\$380.00	\$4,180.00	\$380.00	\$4,180.00	\$3,000.00	\$33,000.00	\$450.00	\$4,950.00
78	Removal of Temporary Sediment Control Basin	11	EA	\$280.00	\$3,080.00	\$280.00	\$3,080.00	\$3,200.00	\$35,200.00	\$450.00	\$4,950.00
79	Maintenance of Temporary Sediment Control Basin	11	EA	\$150.00	\$1,650.00	\$150.00	\$1,650.00	\$3,000.00	\$33,000.00	\$300.00	\$3,300.00
80	Area Inlet Protector	6	EA	\$120.00	\$720.00	\$120.00	\$720.00	\$200.00	\$1,200.00	\$120.00	\$720.00
TOTAL BASE BID				\$2,250,623.32		\$2,490,509.72		\$2,853,415.00		\$2,877,429.52	

Shaded cells with bold font indicates contractor's calculation error

SHIVE-HATTERY, INC.
 2839 Northgate Drive
 Iowa City, Iowa 52245-9568
 (319) 354-3040 FAX (319) 354-6921

TABULATION OF BIDS

Client: City of North Liberty
 Project Name: North Liberty Road Improvements
 S-H Project #: 1161620

Bid Date: **January 16, 2017, 11:00 A.M.**
 Location: **City Admin. Bldg., North Liberty, IA**
 Page No.: **2 of 2**

NAME AND ADDRESS OF BIDDER		Eastern Iowa Excavating & Concrete 121 Nixon St. SE Cascade, Iowa 52033		Portzen Construction Inc. 205 Stone Valley Drive Dubuque, Iowa 52003		Engineer's Estimate				
Addenda Nos. 1 - 2		Yes		Yes						
Bid Security		Yes		Yes						
Bidder Status Form		Yes		Yes						
ITEM	DESCRIPTION	QUANTITY	UNIT PRICE	EXTENDED PRICE	UNIT PRICE	EXTENDED PRICE	UNIT PRICE	EXTENDED PRICE	UNIT PRICE	EXTENDED PRICE
1	Clearing and Grubbing	1,518.3	UNIT	\$19.75	\$29,986.43	\$17.75	\$26,949.83	\$20.00	\$30,366.00	\$0.00
2	Excavation, Class 10, Roadway and Borrow	83,331	CY	\$3.20	\$266,659.20	\$2.50	\$208,327.50	\$5.00	\$416,655.00	\$0.00
3	Topsoil, Strip, Salvage and Spread	20,127	CY	\$3.85	\$77,488.95	\$3.15	\$63,400.05	\$3.00	\$60,381.00	\$0.00
4	Subgrade Stabilization	23,015	SY	\$5.40	\$124,281.00	\$9.25	\$212,888.75	\$7.50	\$172,612.50	\$0.00
5	Modified Subbase	4,240	CY	\$29.00	\$122,960.00	\$34.00	\$144,160.00	\$28.00	\$118,720.00	\$0.00
6	Shoulder Finishing, Earth	6.50	STA	\$220.00	\$1,430.00	\$285.00	\$1,852.50	\$130.00	\$845.00	\$0.00
7	Macadam Stone Base	455	TON	\$25.75	\$11,716.25	\$22.00	\$10,010.00	\$23.00	\$10,465.00	\$0.00
8	Relocation of Mail Boxes	9	EA	\$220.00	\$1,980.00	\$275.00	\$2,475.00	\$250.00	\$2,250.00	\$0.00
9	STD or Slip Form PCC Pavement, CL C, CL 3l Durability, 7 In.	115	SY	\$39.50	\$4,542.50	\$80.00	\$9,200.00	\$40.00	\$4,600.00	\$0.00
10	STD or Slip Form PCC Pavement, CL C, CL 3l Durability, 9 In.	19,420	SY	\$38.50	\$747,670.00	\$45.25	\$878,755.00	\$43.00	\$835,060.00	\$0.00
11	Surfacing, Driveway, Class A Crushed Stone	455	TON	\$15.25	\$6,938.75	\$23.00	\$10,465.00	\$23.00	\$10,465.00	\$0.00
12	Removal of Sign	4	EA	\$50.00	\$200.00	\$77.00	\$308.00	\$58.00	\$232.00	\$0.00
13	Removals, As Per Plan	1	LS	\$3,750.00	\$3,750.00	\$15,000.00	\$15,000.00	\$5,000.00	\$5,000.00	\$0.00
14	Aprons, Concrete, 15 In. Dia.	3	EA	\$1,525.00	\$4,575.00	\$1,200.00	\$3,600.00	\$850.00	\$2,550.00	\$0.00
15	Aprons, Concrete, 18 In. Dia.	6	EA	\$2,250.00	\$13,500.00	\$1,350.00	\$8,100.00	\$1,200.00	\$7,200.00	\$0.00
16	Aprons, Concrete, 24 In. Dia.	1	EA	\$2,950.00	\$2,950.00	\$1,500.00	\$1,500.00	\$1,300.00	\$1,300.00	\$0.00
17	Aprons, Concrete, 48 In. Dia.	1	EA	\$5,500.00	\$5,500.00	\$2,300.00	\$2,300.00	\$2,350.00	\$2,350.00	\$0.00
18	Aprons, Concrete, 54 In. Dia.	2	EA	\$6,000.00	\$12,000.00	\$2,500.00	\$5,000.00	\$2,700.00	\$5,400.00	\$0.00
19	Aprons, Concrete, 60 In. Dia.	2	EA	\$6,900.00	\$13,800.00	\$3,000.00	\$6,000.00	\$3,500.00	\$7,000.00	\$0.00
20	Apron, Low Clearance Concrete, Equivalent Diameter 24 In.	20	EA	\$1,175.00	\$23,500.00	\$950.00	\$19,000.00	\$1,500.00	\$30,000.00	\$0.00
21	Manhole, Storm Sewer, SW-401, 60 In.	2	EA	\$4,250.00	\$8,500.00	\$3,900.00	\$7,800.00	\$5,500.00	\$11,000.00	\$0.00
22	Manhole, Storm Sewer, SW-401, 108 In.	1	EA	\$16,850.00	\$16,850.00	\$14,500.00	\$14,500.00	\$15,000.00	\$15,000.00	\$0.00
23	Intake, SW-509	3	EA	\$3,800.00	\$11,400.00	\$4,600.00	\$13,800.00	\$4,000.00	\$12,000.00	\$0.00
24	Intake, SW-512, 24 In.	2	EA	\$1,375.00	\$2,750.00	\$1,800.00	\$3,600.00	\$1,600.00	\$3,200.00	\$0.00
25	Intake, SW-512, 36 In.	1	EA	\$1,800.00	\$1,800.00	\$2,100.00	\$2,100.00	\$1,800.00	\$1,800.00	\$0.00
26	Intake, SW-513 - 36"x48"	1	EA	\$3,650.00	\$3,650.00	\$5,100.00	\$5,100.00	\$7,500.00	\$7,500.00	\$0.00
27	Intake, SW-513 - 36"x42"	1	EA	\$3,200.00	\$3,200.00	\$4,200.00	\$4,200.00	\$7,000.00	\$7,000.00	\$0.00
28	Intake, SW-513 - 48"x48"	1	EA	\$4,550.00	\$4,550.00	\$5,800.00	\$5,800.00	\$10,000.00	\$10,000.00	\$0.00
29	Intake, SW-513 - 60"x72"	2	EA	\$5,000.00	\$10,000.00	\$6,800.00	\$13,600.00	\$12,000.00	\$24,000.00	\$0.00
30	Intake, SW-513 - 60"x84"	2	EA	\$5,500.00	\$11,000.00	\$8,600.00	\$17,200.00	\$13,000.00	\$26,000.00	\$0.00
31	Subdrain, Longitudinal, (Backslope) 6 In. Dia.	1,910	LF	\$11.50	\$21,965.00	\$15.00	\$28,650.00	\$7.50	\$14,325.00	\$0.00
32	Subdrain, Longitudinal, (Shoulder) 4 In. Dia.	200	LF	\$11.25	\$2,250.00	\$10.00	\$2,000.00	\$5.00	\$1,000.00	\$0.00
33	Subdrain Outlet, DR-303	4	EA	\$475.00	\$1,900.00	\$250.00	\$1,000.00	\$225.00	\$900.00	\$0.00
34	Subdrain Outlet, DR-304	4	EA	\$500.00	\$2,000.00	\$275.00	\$1,100.00	\$350.00	\$1,400.00	\$0.00
35	Special Pipe Connection- Type PC-1	3	EA	\$350.00	\$1,050.00	\$400.00	\$1,200.00	\$350.00	\$1,050.00	\$0.00
36	Subdrain Cleanout, 6 In., As Per Plan	5	EA	\$700.00	\$3,500.00	\$900.00	\$4,500.00	\$420.00	\$2,100.00	\$0.00
37	Storm Sewer Gravity Main, Trenched, RCP 2000D (CL III), 12 In.	17	LF	\$62.85	\$1,068.45	\$95.00	\$1,615.00	\$45.00	\$765.00	\$0.00
38	Storm Sewer Gravity Main, Trenched, RCP 2000D (CL III), 15 In.	268	LF	\$46.50	\$12,462.00	\$80.00	\$21,440.00	\$50.00	\$13,400.00	\$0.00
39	Storm Sewer Gravity Main, Trenched, RCP 2000D (CL III), 18 In.	390	LF	\$55.00	\$21,450.00	\$82.50	\$32,175.00	\$55.00	\$21,450.00	\$0.00
40	Storm Sewer Gravity Main, Trenched, RCP 2000D (CL III), 24 In.	180	LF	\$68.25	\$12,285.00	\$105.00	\$18,900.00	\$60.00	\$10,800.00	\$0.00
41	Storm Sewer Gravity Main, Trenched, RCP 2000D (CL III), 42 In.	26	LF	\$157.50	\$4,095.00	\$190.00	\$4,940.00	\$110.00	\$2,860.00	\$0.00
42	Storm Sewer Gravity Main, Trenched, RCP 2000D (CL III), 48 In.	78	LF	\$172.50	\$13,455.00	\$250.00	\$19,500.00	\$160.00	\$12,480.00	\$0.00
43	Storm Sewer Gravity Main, Trenched, RCP 2000D (CL III), 54 In.	146	LF	\$225.00	\$32,850.00	\$360.00	\$52,560.00	\$190.00	\$27,740.00	\$0.00
44	Storm Sewer Gravity Main, Trenched, RCP 2000D (CL III), 60 In.	227	LF	\$260.00	\$59,020.00	\$515.00	\$116,905.00	\$200.00	\$45,400.00	\$0.00
45	Storm Sewer Gravity Main, Trenched, 2000D Low Clearance Concrete Pipe, Equiv. Dia. 24 In.	241	LF	\$120.00	\$28,920.00	\$105.00	\$25,305.00	\$165.00	\$39,765.00	\$0.00
46	Remove Storm Sewer Pipe Less Than or Equal to 36 In.	373	LF	\$11.00	\$4,103.00	\$16.00	\$5,968.00	\$13.00	\$4,849.00	\$0.00
47	Remove Storm Sewer Pipe Greater Than 36 In.	243	LF	\$14.00	\$3,402.00	\$35.00	\$8,505.00	\$25.00	\$6,075.00	\$0.00
48	Remove and Reinstall Storm Sewer Pipe Less Than or Equal to 36 In.	27	LF	\$41.50	\$1,120.50	\$95.00	\$2,565.00	\$30.00	\$810.00	\$0.00
49	Revetment, Class E	1,225	TON	\$40.50	\$49,612.50	\$39.00	\$47,775.00	\$39.00	\$47,775.00	\$0.00
50	Erosion Stone	861	TON	\$23.50	\$20,233.50	\$27.50	\$23,677.50	\$25.00	\$21,625.00	\$0.00
51	Backfill for Retaining Wall	1,600	TON	\$31.50	\$50,400.00	\$7.00	\$11,200.00	\$20.00	\$32,000.00	\$0.00
52	Segmental Block Retaining Wall	2,680	SF	\$57.00	\$152,760.00	\$42.00	\$112,560.00	\$50.00	\$134,000.00	\$0.00
53	Removal of Pavement	169	SY	\$10.80	\$1,825.20	\$11.00	\$1,859.00	\$10.00	\$1,690.00	\$0.00
54	Driveway, P.C. Concrete, 6 In.	385	SY	\$41.85	\$16,112.25	\$48.00	\$18,480.00	\$40.00	\$15,400.00	\$0.00
55	Fence, Chain Link, 48 In. Height	318	LF	\$25.00	\$7,950.00	\$27.50	\$8,745.00	\$30.00	\$9,540.00	\$0.00
56	Fence, Field - Temporary	6,000	LF	\$8.25	\$49,500.00	\$4.05	\$24,300.00	\$3.00	\$18,000.00	\$0.00
57	Fence, Field	7,730	LF	\$7.25	\$56,042.50	\$8.75	\$67,637.50	\$7.00	\$54,110.00	\$0.00
58	Gate, Field Fence, 16 Ft.	8	EA	\$1,050.00	\$8,400.00	\$850.00	\$6,800.00	\$1,000.00	\$8,000.00	\$0.00
59	Removal of Fence, Field	7,900	LF	\$2.25	\$17,775.00	\$3.00	\$23,700.00	\$2.00	\$15,800.00	\$0.00
60	Remove and Reinstall Sign As Per Plan	10	EA	\$165.00	\$1,650.00	\$150.00	\$1,500.00	\$100.00	\$1,000.00	\$0.00
61	Perforated Square Steel Tube Posts	96	LF	\$11.00	\$1,056.00	\$10.50	\$1,008.00	\$15.00	\$1,440.00	\$0.00
62	Perforated Square Steel Tube Post Anchor, Break-Away Soil Installation	7	EA	\$190.00	\$1,330.00	\$200.00	\$1,400.00	\$215.00	\$1,505.00	\$0.00
63	Type A Signs, Sheet Aluminum	35	SF	\$19.00	\$665.00	\$19.00	\$665.00	\$23.00	\$805.00	\$0.00
64	Painted Pavement Markings, Durable	212	STA	\$77.00	\$16,324.00	\$75.00	\$15,900.00	\$60.00	\$12,720.00	\$0.00
65	Traffic Control	1	LS	\$11,500.00	\$11,500.00	\$6,600.00	\$6,600.00	\$10,000.00	\$10,000.00	\$0.00
66	Mobilization	1	LS	\$164,500.00	\$164,500.00	\$225,000.00	\$225,000.00	\$100,000.00	\$100,000.00	\$0.00
67	Temporary Access Drives	1	LS	\$12,000.00	\$12,000.00	\$11,500.00	\$11,500.00	\$10,000.00	\$10,000.00	\$0.00
68	Compost Filter Tube (8 In. Dia.) or Silt Fence	15,400	LF	\$1.70	\$26,180.00	\$1.65	\$25,410.00	\$1.50	\$23,100.00	\$0.00
69	Biodegradable Erosion Control Blanket	8,855	SQ	\$28.00	\$247,940.00	\$13.50	\$119,542.50	\$13.00	\$115,115.00	\$0.00
70	Hydraulic Seeding, Fertilizing and Mulching - Type 1	2.50	ACRE	\$4,500.00	\$11,250.00	\$3,900.00	\$9,750.00	\$3,750.00	\$9,375.00	\$0.00
71	Hydraulic Seeding, Fertilizing and Mulching - Type 2	17.80	ACRE	\$4,700.00	\$83,660.00	\$3,500.00	\$62,300.00	\$3,250.00	\$57,850.00	\$0.00
72	Stabilizing Crop - Seeding, Fertilizing and Mulching - Type 4	20	ACRE	\$785.00	\$15,700.00	\$500.00	\$10,000.00	\$500.00	\$10,000.00	\$0.00
73	Permeable Ditch Checks	4,200	LF	\$7.25	\$30,450.00	\$6.00	\$25,200.00	\$6.00	\$25,200.00	\$0.00
74	Removal of Compost Filter Tube, Silt Fence or Ditch Checks	19,600	LF	\$0.55	\$10,780.00	\$0.20	\$3,920.00	\$0.25	\$4,900.00	\$0.00
75	Maintenance of Compost Filter Tube, Silt Fence or Ditch Checks	19,600	LF	\$0.55	\$10,780.00	\$0.10	\$1,960.00	\$0.50	\$9,800.00	\$0.00
76	Mobilization, Erosion Control	15	EA	\$725.00	\$10,875.00	\$275.00	\$4,125.00	\$250.00	\$3,750.00	\$0.00
77	Temporary Sediment Control Basin	11	EA	\$480.00	\$5,280.00	\$425.00	\$4,675.00	\$1,363.64	\$15,000.04	\$0.00
78	Removal of Temporary Sediment Control Basin	11	EA	\$480.00	\$5,280.00	\$305.00	\$3,355.00	\$1,363.64	\$15,000.04	\$0.00
79	Maintenance of Temporary Sediment Control Basin	11	EA	\$320.00	\$3,520.00	\$165.00	\$1,815.00	\$1,000.00	\$11,000.00	\$0.00
80	Area Inlet Protector	6	EA	\$95.00	\$570.00	\$135.00	\$810.00	\$300.00	\$1,800.00	\$0.00
TOTAL BASE BID				\$2,878,024.98		\$2,948,989.13		\$2,845,320.58		\$0.00

Shaded cells with bold font indicates contractor's calculation error

Resolution No. 2017-06

RESOLUTION ACCEPTING THE BID AND AUTHORIZING EXECUTION OF THE CONTRACT FOR THE NORTH LIBERTY ROAD IMPROVEMENTS PROJECT, NORTH LIBERTY, IOWA

BE IT RESOLVED BY THE CITY COUNCIL OF THE CITY OF NORTH LIBERTY, IOWA:

WHEREAS, the City Council sought bids for the North Liberty Road Improvements Project;

WHEREAS, six bidders submitted responsive bids for the project; and

WHEREAS, the lowest responsible bid was Metro Pavers, Inc. with a Lump Sum Bid Price of \$2,250,623.32; and

NOW, THEREFORE, BE IT RESOLVED that the North Liberty Road Improvements Project is authorized and the bid from Metro Pavers, Inc. is hereby accepted and approved for the project at a bid amount of \$2,250,623.32 is hereby approved as set forth therein.

BE IT FURTHER RESOLVED that the Contract between the Owner and the Contractor is approved and that the Mayor is authorized to execute said agreement.

APPROVED AND ADOPTED this 24th day of January, 2017.

CITY OF NORTH LIBERTY:

ATTEST:

TERRY L. DONAHUE, MAYOR PRO TEM

TRACEY MULCAHEY, CITY CLERK

Logan Supply Company Site Plan





January 4, 2017

Recommended for approval by Planning Commission at their meeting of 1/11/2017.

Memo

To: North Liberty Planning Commission
From: Dean Wheatley, Planning Director
Subject: Site Plan Approval Request
(Lot 2, Resubdivision of Lot 13, I-380 Industrial Park)

Your North Liberty city staff has reviewed the subject submission, and offer comments presented in this memo. The staff review team includes the following personnel:

Ryan Heiar, City Administrator
Tracey Mulcahey, Assistant City Administrator
Tom Palmer, City Building Official
Scott Peterson, City Attorney
Kevin Trom, City Engineer
Dean Wheatley, Planning Director

This request is to approve a site plan located west of Interstate I-380, near the south end of Stoner Court.

The site, zoned I1 (Light Industrial), is proposed to be developed for a contractors' supply store. The layout provides good pedestrian and vehicular circulation, with ample parking and what appears to be a large outside storage area. Landscaping is provided to satisfy the requirement for outside storage screening.

The building is a clean modern design with attractive materials and design, featuring the use of varied materials, well-placed windows and doors, and an attractive and distinctive entrance treatment.

Staff recommends approval of the site plan.

Notes:

- Verification that the parking lot and drive is designed to support a gross axle weight of 75,000lb. is required.
- Building Construction type was not provided so construction Type VB was used. To accurately determine the needed fire flow, the building construction type and if the building will be protected by a fire sprinkler system is needed. Based on a type VB construction and 15,000 square feet, (4) fire hydrants are needed. Only (2) fire hydrants are shown on the site plan.
- If a gate will be used in the parking lot, please notify the Fire Department for further requirements for site access.

SITE PLAN

LOT 2, RESUBDIVISION OF LOT 13, I-380 INDUSTRIAL PARK

2755 STONER COURT NORTH LIBERTY, IOWA

5.63 AC.



CIVIL ENGINEERS
LAND PLANNERS
LAND SURVEYORS
LANDSCAPE ARCHITECTS
ENVIRONMENTAL SPECIALISTS

1917 S. GILBERT ST.
IOWA CITY, IOWA 52240
(319) 351-8282
www.mmsconsultants.net

PLAT PREPARED BY: MMS CONSULTANTS INC.
1917 S. GILBERT STREET
IOWA CITY, IA 52240

APPLICANT: LOGAN CONTRACTOR SUPPLY
4101 106 ST
URBANDALE, IA 50322

OWNERS ATTORNEY: NYEMASTER GOODE PC
700 WALNUT STREET, SUITE 1600
DES MOINES, IA 50309

STANDARD LEGEND AND NOTES

---	PROPERTY &/or BOUNDARY LINES
---	CONGRESSIONAL SECTION LINES
---	RIGHT-OF-WAY LINES
---	EXISTING RIGHT-OF-WAY LINES
---	CENTER LINES
---	EXISTING CENTER LINES
---	LOT LINES, INTERNAL
---	LOT LINES, PLATTED OR BY DEED
---	PROPOSED EASEMENT LINES
---	EXISTING EASEMENT LINES
---	BENCHMARK
---	RECORDED DIMENSIONS
---	CURVE SEGMENT NUMBER

EXIST-	PROP-	22-1	POWER POLE
⊙	⊙	⊙	POWER POLE W/DROP
⊙	⊙	⊙	POWER POLE W/TRANS
⊙	⊙	⊙	POWER POLE W/LIGHT
⊙	⊙	⊙	GUY POLE
⊙	⊙	⊙	LIGHT POLE
⊙	⊙	⊙	SANITARY MANHOLE
⊙	⊙	⊙	FIRE HYDRANT
⊙	⊙	⊙	WATER VALVE
⊙	⊙	⊙	DRAINAGE MANHOLE
⊙	⊙	⊙	CURB INLET
⊙	⊙	⊙	FENCE LINE
⊙	⊙	⊙	EXISTING SANITARY SEWER
⊙	⊙	⊙	PROPOSED SANITARY SEWER
⊙	⊙	⊙	EXISTING STORM SEWER
⊙	⊙	⊙	PROPOSED STORM SEWER
⊙	⊙	⊙	WATER LINES
⊙	⊙	⊙	ELECTRICAL LINES
⊙	⊙	⊙	TELEPHONE LINES
⊙	⊙	⊙	GAS LINES
⊙	⊙	⊙	CONTOUR LINES (1' INTERVAL)
⊙	⊙	⊙	PROPOSED GROUND
⊙	⊙	⊙	EXISTING TREE LINE
⊙	⊙	⊙	EXISTING DECIDUOUS TREE & SHRUB
⊙	⊙	⊙	EXISTING EVERGREEN TREES & SHRUBS

THE ACTUAL SIZE AND LOCATION OF ALL PROPOSED FACILITIES SHALL BE VERIFIED WITH CONSTRUCTION DOCUMENTS, WHICH ARE TO BE PREPARED AND SUBMITTED SUBSEQUENT TO THE APPROVAL OF THIS DOCUMENT.

KEYNOTES

NUMBER	KEYNOTE
1	INSTALL DRIVE PER DETAIL (THICKNESS AND MATERIAL AS NOTED)
2	DUMPSTER ENCLOSURE PER DETAIL
3	GRIND EXISTING CURB AND INSTALL TYPE A ENTRANCE PER SUDAS DETAIL 7030.101
4	ACCESSIBLE PARKING SIGN, RAMP AND STRIPING
5	CURB STOP, TYP OF 6
6	INSTALL SIDEWALK PER CITY OF NORTH LIBERTY STANDARDS
7	INSTALL 6" STANDARD CURB
8	TRANSITION FROM 6" STANDARD CURB TO NO CURB
9	INSTALL 8" CLASS 2B FUSED AND BONDED VINYL COATED GAUGE CHAIN LINK FENCE PANELS WITH MINIMUM 9 GAUGE CORE, WITH 2" MESH, AND WINGED TYPE SLATS INSTALLED TO OBTAIN A PRIVACY FACTOR OF 90% OR GREATER MAY BE USED AS A SUBSTITUTE FOR A SOLID FACE.
10	6' TALL WOODEN FENCE

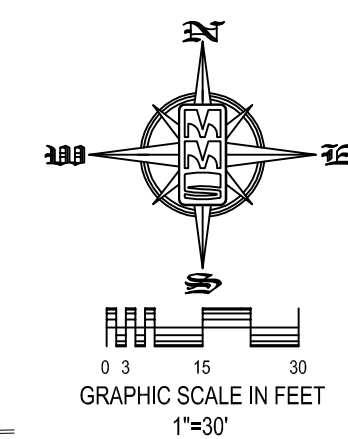

LEGAL DESCRIPTION:
Lot 2, Resubdivision of Lot 13, I-380 Industrial Park, North Liberty, Iowa, according to the plat thereof recorded in Book 49, Page 61, Plat Records of Johnson County, Iowa.

AREA CALCULATIONS:

TRACT AREA	245,123 SF	(5.63 AC)
PROPOSED PAVED AREA	59,502 SF	(24.3%)
PROPOSED BUILDING AREA	15,000 SF	(6.1%)
TOTAL IMPERVIOUS AREA	74,502 SF	(30.4%)
OPEN AREA	170,621 SF	(69.6%)

PARKING REQUIREMENTS:

PARKING REQUIRED FIRST FLOOR:

RETAIL: 1 SPACE / 200 SF BUILDING
@ 1,550 SF = 18 SPACES

WAREHOUSE: 1 SPACE / 2,000 SF BUILDING
@ 5,980 SF = 3 SPACES (+0 EMPLOYEES)

SERVICE BAYS: 1 SPACE / 300 SF BUILDING
@ 2,560 SF = 9 SPACES (+1 EMPLOYEE)

OFFICES/SUPPORT: 1 SPACE / 200 SF BUILDING
@ 2,910 SF = 15 SPACES

MEZZANINE:
OFFICE/SUPPORT: 1 SPACE / 200 SF BUILDING
@ 1,350 SF = 7 SPACES

UNOCCUPIED: 1 SPACE / 2,000 SF BUILDING
@ 1,400 SF = 1 SPACES

TOTAL PARKING REQUIRED = 54 SPACES
TOTAL PARKING PROVIDED = 51 REGULAR SPACES
= 3 ACCESSIBLE SPACE
= 54 SPACES TOTAL

EXISTING ZONING = I-1 (INDUSTRIAL)

SETBACK REQUIREMENTS:

BUILDING SETBACKS
FRONT - 25'
SIDE - 20'
REAR - 20'

BENCHMARK INFORMATION

POINT	ELEVATION	DATUM	DESCRIPTION
NO. 702	792.984'	NAVD88	CUT X ON INTAKE LOCATED ON WEST SIDE OF STREET APPROXIMATELY 35' SOUTH OF NORTH PROPERTY LINE.
NO. 701	791.132'	NAVD88	CUT X ON INTAKE LOCATED ON WEST SIDE OF STREET APPROXIMATELY 105' NORTH OF SOUTH PROPERTY LINE.

HORIZONTAL CONTROL

POINT	NORTHING	EASTING	DESCRIPTION
H1	642410.78	2146639.11	SEE BENCHMARK NO. 1
H2	642069.27	2146646.28	SEE BENCHMARK NO. 2
H3	642618.36	2146645.38	CUT X IN STREET PAVEMENT APPROXIMATELY 365' NORTH OF NORTH PROPERTY LINE

PAVING LEGEND

(QUANTITIES SHOWN IN THIS PAVING LEGEND ARE FOR ENTIRE PROJECT, INCLUDING WORK WITHIN RIGHT OF WAY)

	7" PCC PAVING (6,605 SY) w/ 6" AGGREGATE SUB-BASE
	5" PCC PAVING (349 SY)

UTILITIES

THE CONTRACTOR SHALL NOTIFY IOWA ONE CALL NO LESS THAN 48 HRS. IN ADVANCE OF ANY DIGGING OR EXCAVATION.

WHERE PUBLIC UTILITY FIXTURES ARE SHOWN AS EXISTING ON THE PLANS OR ENCOUNTERED WITHIN THE CONSTRUCTION AREA, IT SHALL BE THE RESPONSIBILITY OF THE CONTRACTOR TO NOTIFY THE OWNERS OF THOSE UTILITIES PRIOR TO THE BEGINNING OF ANY CONSTRUCTION. THE CONTRACTOR SHALL AFFORD ACCESS TO THESE FACILITIES FOR NECESSARY MODIFICATION OF SERVICES. UNDERGROUND FACILITIES, STRUCTURES AND UTILITIES HAVE BEEN PLOTTED FROM AVAILABLE SURVEYS AND RECORDS, AND THEREFORE THEIR LOCATIONS MUST BE CONSIDERED APPROXIMATE ONLY. IT IS POSSIBLE THERE MAY BE OTHERS, THE EXISTENCE OF WHICH IS PRESENTLY NOT KNOWN OR SHOWN. IT IS THE CONTRACTOR'S RESPONSIBILITY TO DETERMINE THEIR EXISTENCE AND EXACT LOCATION AND TO AVOID DAMAGE THERETO. NO CLAIMS FOR ADDITIONAL COMPENSATION WILL BE ALLOWED TO THE CONTRACTOR FOR ANY INTERFERENCE OR DELAY CAUSED BY SUCH WORK.

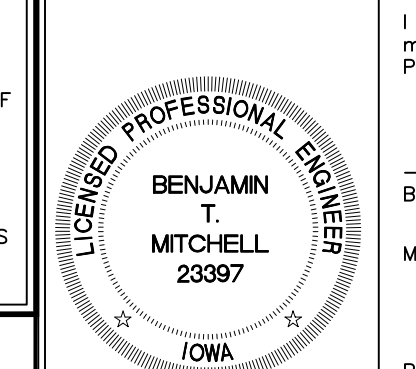

I hereby certify that this engineering document was prepared by me or under my direct supervision and that I am a duly licensed Professional Engineer under the laws of the State of Iowa.

BENJAMIN T. MITCHELL, P.E. Iowa Lic. No. 23397

My license renewal date is December 31, 20 ____.

Pages of sheets covered by this seal: _____

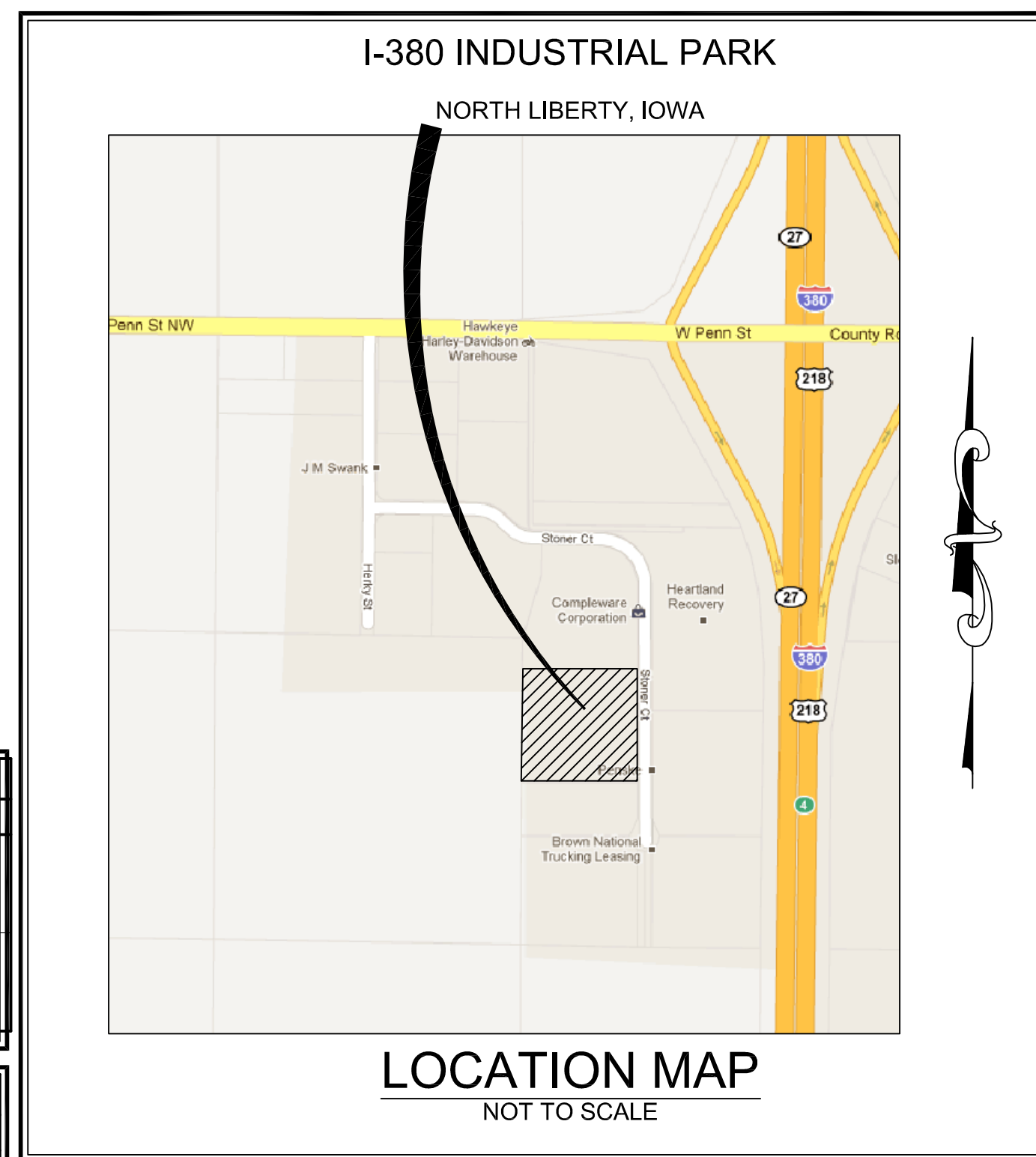

Date	Revision
12-21-16	PER CITY COMMENTS - NPB
01-05-17	PER CITY COMMENTS - BTM

SITE LAYOUT PLAN

LOGAN CONTRACTORS SUPPLY
LOT 2, RESUBDIVISION OF LOT 13,
I-380 INDUSTRIAL PARK
NORTH LIBERTY
JOHNSON COUNTY
IOWA

MMS CONSULTANTS, INC.

Date:	12-01-2016
Designed By:	BTM
Drawn By:	BTM
Checked By:	BTM
Project No.:	IOWA CITY 6763011
Field Book No.:	1053/59-62
Scale:	1"=30'
Sheet No.:	1
of:	5

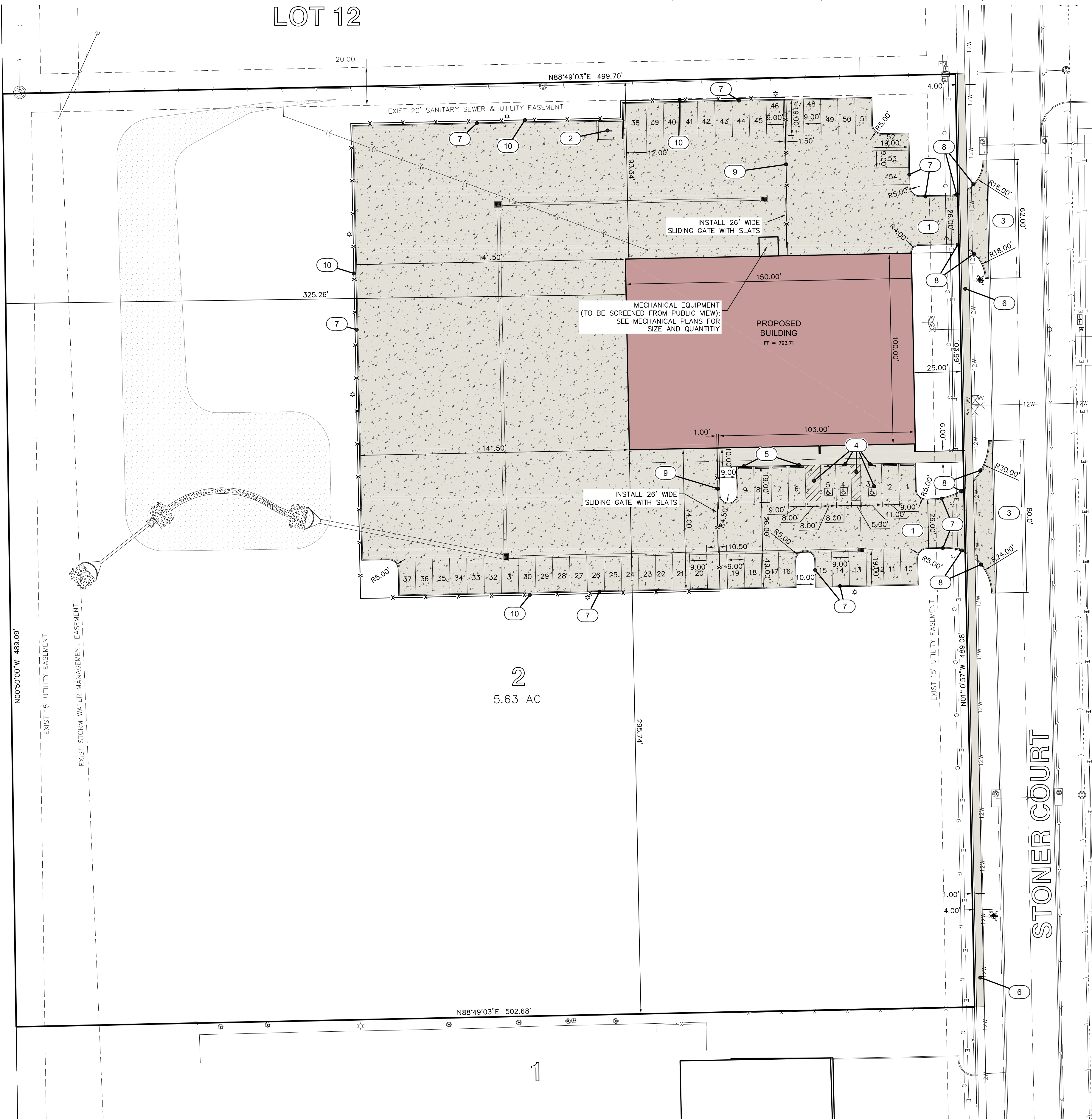

SITE PLAN

LOT 2, RESUBDIVISION OF LOT 13, I-380 INDUSTRIAL PARK

2755 STONER COURT
NORTH LIBERTY, IOWA



CIVIL ENGINEERS
LAND PLANNERS
LAND SURVEYORS
LANDSCAPE ARCHITECTS
ENVIRONMENTAL SPECIALISTS

1917 S. GILBERT ST.
IOWA CITY, IOWA 52240
(319) 351-8282
www.mmsconsultants.net

Date	Revision
12-21-16	PER CITY COMMENTS - NPB
01-05-17	PER CITY COMMENTS - BTM

STANDARD LEGEND AND NOTES

- PROPERTY &/or BOUNDARY LINES
- CONGRESSIONAL SECTION LINES
- RIGHT-OF-WAY LINES
- EXISTING RIGHT-OF-WAY LINES
- CENTER LINES
- EXISTING CENTER LINES
- LOT LINES, INTERNAL
- LOT LINES, PLATTED OR BY DEED
- PROPOSED EASEMENT LINES
- EXISTING EASEMENT LINES
- BENCHMARK
- RECORDED DIMENSIONS
- CURVE SEGMENT NUMBER

EXIST - POWER POLE
PROP - POWER POLE W/DROP
PROP - POWER POLE W/TRANS
PROP - POWER POLE W/LIGHT
PROP - GUY POLE
PROP - LIGHT POLE
PROP - SANITARY MANHOLE
PROP - FIRE HYDRANT
PROP - WATER VALVE
PROP - DRAINAGE MANHOLE
PROP - CURB INLET
PROP - FENCE LINE
PROP - EXISTING SANITARY SEWER
PROP - PROPOSED SANITARY SEWER
PROP - EXISTING STORM SEWER
PROP - PROPOSED STORM SEWER
PROP - WATER LINES
PROP - ELECTRICAL LINES
PROP - TELEPHONE LINES
PROP - GAS LINES
PROP - CONTOUR LINES (1' INTERVAL)
PROP - PROPOSED GROUND
PROP - EXISTING TREE LINE
PROP - EXISTING DECIDUOUS TREE & SHRUB
PROP - EXISTING EVERGREEN TREES & SHRUBS

THE ACTUAL SIZE AND LOCATION OF ALL PROPOSED FACILITIES SHALL BE VERIFIED WITH CONSTRUCTION DOCUMENTS, WHICH ARE TO BE PREPARED AND SUBMITTED SUBSEQUENT TO THE APPROVAL OF THIS DOCUMENT.

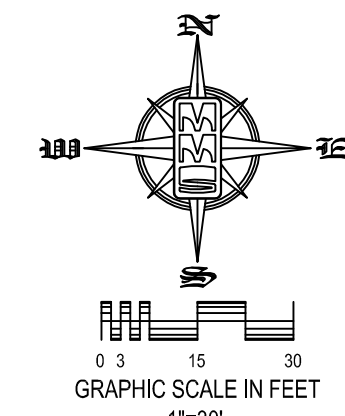

PERMANENT SEEDING PER SUDAS SPEC SECTION 9010. USE PERMANENT SEED MIX FOR SLOPES AND DITCHES PER SECTION 9010.2.02.B.

EROSION CONTROL LEGEND

- SILT FENCE/FILTER SOCK
- TEMPORARY ROCK CONSTRUCTION ENTRANCE/EXIT
- TEMPORARY PARKING AND STORAGE
- CONCRETE TRUCK/EQUIPMENT WASHOUT
- PORTABLE RESTROOM
- DOCUMENT LOCATION (PERMITS, SWPPP, INSPECTION FORMS, ETC.)
- FILTER SOCK INLET PROTECTION
- FILTER SOCK BEHIND CURB AT CURB RAMP
- PERIMETER SILT FENCE
- TEMPORARY SOIL STOCKPILE AREA
- DIRECTION OF OVERLAND FLOW
- DUMPSTER FOR CONSTRUCTION WASTE
- RIP RAP OUTLET PROTECTION
- OTHER MEASURE: _____
- OTHER MEASURE: _____
- OTHER MEASURE: _____

THE ABOVE LISTED ITEMS ARE SHOWN IN THEIR RECOMMENDED LOCATIONS. IF A CONTROL MEASURE IS ADDED OR MOVED TO A MORE SUITABLE LOCATION, INDICATE THE REVISION ON THIS SHEET. THE BLANKS LEFT FOR OTHER MEASURES SHOULD BE USED IF AN ITEM NOT SHOWN ABOVE IS IMPLEMENTED ON SITE. ADDITIONAL PRACTICES FOR EROSION PREVENTION AND SEDIMENT CONTROL CAN BE FOUND IN APPENDIX D OF THE SWPPP.

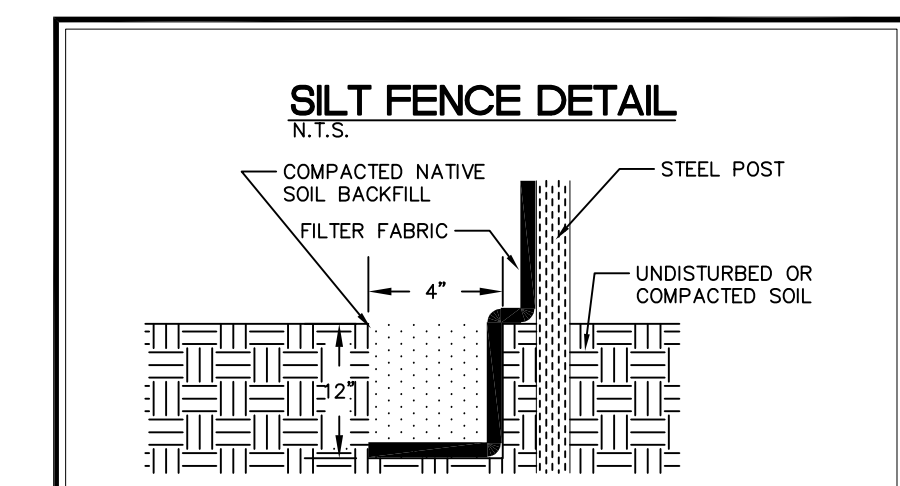

- #### INSTALLATION
- POSTS SHALL BE 1.33 POUNDS PER LINEAL FOOT STEEL WITH A MINIMUM LENGTH OF 5 FEET. STEEL POSTS SHALL HAVE PROJECTIONS FOR FASTENING WIRE TO THEM.
 - SILT FENCE FABRIC SHALL CONFORM TO I.D.O.T. STANDARD SPECIFICATION SECTION 4196.01.A. SILT FENCING SHALL BE A MINIMUM OF 24" AND A MAXIMUM OF 36" HIGH WHEN COMPLETE.
 - THE FILTER FABRIC SHALL BE PURCHASED IN A CONTINUOUS ROLL CUT TO THE LENGTH OF THE FENCE TO AVOID THE USE OF JOINTS. WHEN JOINTS ARE NECESSARY, THE FILTER CLOTH SHALL BE SPUN TOGETHER ONLY AT A SUPPORT POST.
 - POSTS SHALL BE SPACED A MAXIMUM OF 8 FEET APART AND DRIVEN SECURELY INTO THE GROUND ALONG THE FENCE ALIGNMENT. POSTS SHALL BE DRIVEN INTO THE GROUND A MINIMUM OF 28".
 - A TRENCH SHALL BE EXCAVATED APPROXIMATELY 4" WIDE BY 12" DEEP ALONG THE UPSLOPE SIDE OF THE POSTS.
 - FILTER FABRIC SHALL BE STAPLED OR WIRED TO THE POSTS SUCH THAT THE FABRIC EXTENDS INTO THE TRENCH AS SHOWN ABOVE. THE FABRIC SHALL BE FASTENED A MINIMUM OF THREE PLACES ON EACH POST.
 - THE TRENCH SHALL BE BACK FILLED WITH EXCAVATED MATERIAL AND THOROUGHLY COMPACTED.

- #### MAINTENANCE
- SILT FENCES SHALL BE INSPECTED WEEKLY AND AFTER EACH RAIN-FALL EVENT OF 0.5 INCHES OR MORE. DURING PERIODS OF PROLONGED RAIN INSPECTIONS SHALL BE AT LEAST DAILY. ANY REPAIRS NEEDED TO MAINTAIN THE SILT FENCE'S EFFECTIVENESS SHALL BE MADE IMMEDIATELY.
 - SHOULD THE FABRIC ON A SILT FENCE DECOMPOSE OR BECOME INEFFECTIVE PRIOR TO STABILIZING THE UPSLOPE AREAS THE FABRIC SHALL BE REPLACED PROMPTLY.
 - SEDIMENT DEPOSITS SHOULD BE REMOVED AFTER EACH STORM EVENT. THEY MUST BE REMOVED WHEN THE DEPOSITS REACH APPROXIMATELY ONE-HALF THE HEIGHT OF THE FENCE. SILTS REMOVED SHALL BE PLACED IN A PROTECTED PLACE THAT WILL PREVENT THEIR ESCAPE FROM THE CONSTRUCTION SITE.
 - ANY SEDIMENT DEPOSITS REMAINING IN PLACE AFTER THE SILT FENCE IS NO LONGER NEEDED SHALL BE DRESSED TO CONFORM WITH THE EXISTING GRADE, PREPARED AND SEED.
 - SILT FENCE SHALL REMAIN IN PLACE UNTIL IT IS NO LONGER NEEDED AS DIRECTED BY THE POLLUTION PREVENTION PLAN. GENERALLY SILT FENCES SHALL REMAIN UNTIL THE UPSLOPE AREAS ARE STABILIZED WITH AN ESTABLISHED GRASS COVER AS A MINIMUM.

SHEET INDEX

- 1 SITE LAYOUT PLAN
- 2 SITE GRADING AND EROSION CONTROL PLAN
- 3 SITE UTILITY PLAN
- 4 SITE LANDSCAPE PLAN
- 5 GENERAL NOTES AND DETAILS

THE CONTRACTOR SHALL PROVIDE TRAFFIC CONTROL PER IDOT STANDARD ROAD PLANS AND CITY OF NORTH LIBERTY REQUIREMENTS AT ALL TIMES DURING WORK WITHIN PUBLIC R.O.W.

THE CONTRACTOR SHALL COORDINATE WITH UTILITY PROVIDERS FOR ANY REQUIRED RELOCATION OF EXISTING UTILITIES.

GRADING TOPSOIL NOTE:
PRIOR TO FINAL SEEDING, ALL GREEN SPACE SHALL BE TILLED TO A MINIMUM DEPTH OF 12" AND COVERED WITH A MINIMUM OF 6" OF TOPSOIL. CONTRACTOR SHALL BE RESPONSIBLE FOR STOCKPILING ADEQUATE TOPSOIL FOR ALL GREEN SPACE.

GRADING AND EROSION CONTROL NOTES

TOTAL SITE AREA: -- ACRES
TOTAL AREA TO BE DISTURBED: 5.63 ACRES

EROSION CONTROL MEASURES SHOWN SHALL BE USED DURING FILL ACTIVITIES. EROSION CONTROL MEASURES SHALL BE REEVALUATED AND MODIFIED, IF NECESSARY, AT THE TIME OF SITE DEVELOPMENT.

ADDITIONAL EROSION AND SEDIMENT CONTROL MEASURES THAT COULD BE USED ON SITE, IF NEEDED, CAN BE FOUND IN APPENDIX D OF THE STORM WATER POLLUTION PREVENTION PLAN (SWPPP) BINDER PREPARED FOR THE SITE. IF ADDITIONAL MEASURES ARE USED, INDICATE THE TYPE AND LOCATION OF SAID MEASURE ON THIS PLAN.

CONTRACTOR SHALL INSTALL A ROCK ENTRANCE AND PERFORM REGULAR CLEANING OF VEHICLES THAT LEAVE THE SITE.

FOLLOWING INSTALLATION OF PERIMETER SILT FENCE AND TEMPORARY CONSTRUCTION ENTRANCE THE CONTRACTOR SHALL CONTACT THE CITY INSPECTOR TO SCHEDULE A SITE INSPECTION PRIOR TO ANY SOIL DISTURBING ACTIVITIES.

THE CONTRACTOR SHALL FOLLOW THE NPDES PERMIT, SWPPP, AND THE CITY CSR REGULATIONS.

THE EROSION CONTROL CONTRACTOR SHALL INSTALL FILTER SOCKS OR OTHER APPROVED FORM OF INLET PROTECTION AT EACH STREET INTAKE ADJACENT TO THE SITE.

STABILIZATION SEEDING

STABILIZATION SEEDING SHALL BE IN ACCORDANCE WITH SUDAS SECTION 9010.2.02 SEED MIXTURES AND SEEDING DATES.

TABLE 9010.06: TYPE 4 SEED MIXTURE

COMMON NAME	APPLICATION RATE lb/acre
SPRING - MARCH 1 - MAY 20	
ANNUAL RYEGRASS	40
OATS*	65
SUMMER - MAY 21 - AUGUST 14	
ANNUAL RYEGRASS	50
OATS*	95
FALL - AUGUST 15 - SEPTEMBER 30	
ANNUAL RYEGRASS	40
GRAIN RYE	65

* ENGINEER MAY DELETE FOR PREVIOUSLY ESTABLISHED URBAN AREAS.

FERTILIZER SHALL BE APPLIED AT A RATE OF 300 LBS PER ACRE USING CHEMICALLY COMBINED COMMERCIAL 13-13-13 FERTILIZER (SUDAS SECTION 9010.2.03 A.2)

SITE GRADING AND EROSION CONTROL PLAN

LOGAN CONTRACTORS SUPPLY
LOT 2, RESUBDIVISION OF LOT 13,
I-380 INDUSTRIAL PARK
NORTH LIBERTY
JOHNSON COUNTY
IOWA

MMS CONSULTANTS, INC.
Date: 12-01-2016
Designed By: BTM Field Book No: 1053/59-62
Drawn By: BTM Scale: 1"=30'
Checked By: BTM Sheet No: 2
Project No: IOWA CITY 6763011 of 5

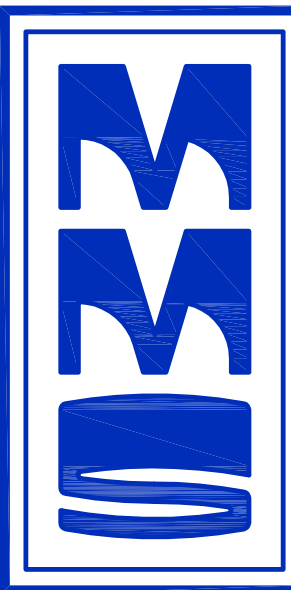

CIVIL ENGINEERS
LAND PLANNERS
LAND SURVEYORS
LANDSCAPE ARCHITECTS
ENVIRONMENTAL SPECIALISTS

1917 S. GILBERT ST.
IOWA CITY, IOWA 52240
(319) 351-8282
www.mmsconsultants.net

Date	Revision
12-21-16	PER CITY COMMENTS - NPB
01-05-17	PER CITY COMMENTS - BTM

SITE PLAN

LOT 2, RESUBDIVISION OF LOT 13, I-380 INDUSTRIAL PARK

2755 STONER COURT NORTH LIBERTY, IOWA

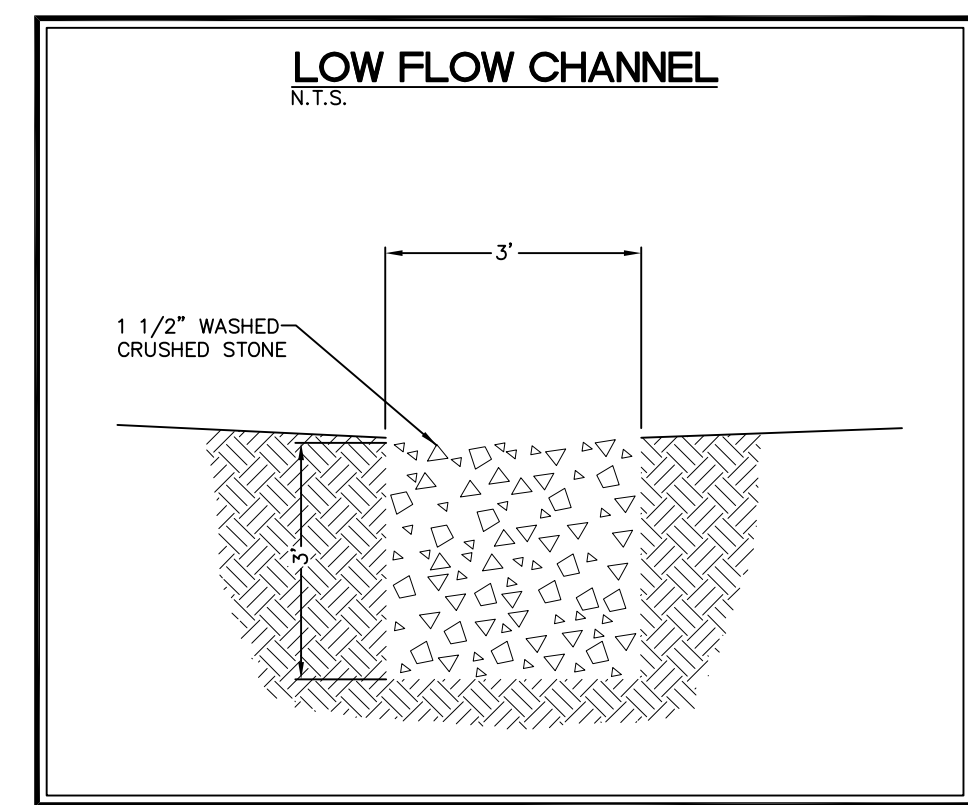
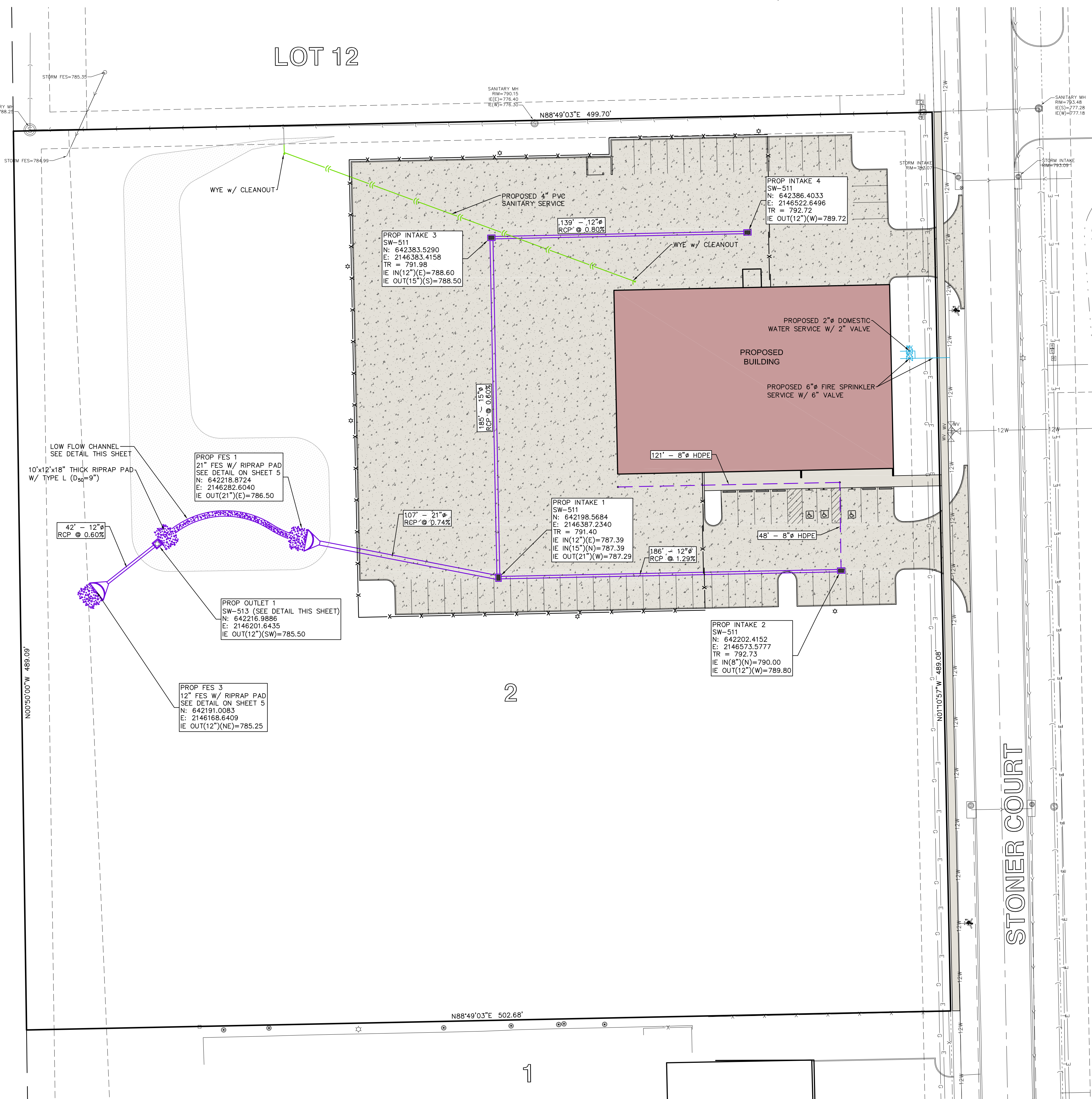
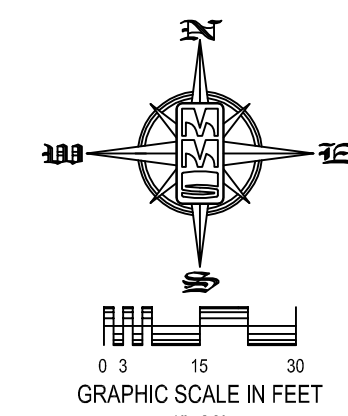

STANDARD LEGEND AND NOTES

---	PROPERTY &/OR BOUNDARY LINES
---	CONGRESSIONAL SECTION LINES
---	RIGHT-OF-WAY LINES
---	EXISTING RIGHT-OF-WAY LINES
---	CENTER LINES
---	EXISTING CENTER LINES
---	LOT LINES, INTERNAL
---	LOT LINES, PLATTED OR BY DEED
---	PROPOSED EASEMENT LINES
---	EXISTING EASEMENT LINES
---	BENCHMARK
---	RECORDED DIMENSIONS
---	CURVE SEGMENT NUMBER
---	22-1
---	EXIST-
---	PROP-
---	POWER POLE W/DROP
---	POWER POLE W/TRANS
---	POWER POLE W/LIGHT
---	GUY POLE
---	LIGHT POLE
---	SANITARY MANHOLE
---	FIRE HYDRANT
---	WATER VALVE
---	DRAINAGE MANHOLE
---	CURB INLET
---	FENCE LINE
---	EXISTING SANITARY SEWER
---	PROPOSED SANITARY SEWER
---	EXISTING STORM SEWER
---	PROPOSED STORM SEWER
---	WATER LINES
---	PROPOSED WATER LINES
---	ELECTRICAL LINES
---	TELEPHONE LINES
---	GAS LINES
---	CONTOUR LINES (1' INTERVAL)
---	PROPOSED GROUND
---	EXISTING TREE LINE
---	EXISTING DECIDUOUS TREE & SHRUB
---	EXISTING EVERGREEN TREES & SHRUBS

THE ACTUAL SIZE AND LOCATION OF ALL PROPOSED FACILITIES SHALL BE VERIFIED WITH CONSTRUCTION DOCUMENTS, WHICH ARE TO BE PREPARED AND SUBMITTED SUBSEQUENT TO THE APPROVAL OF THIS DOCUMENT.

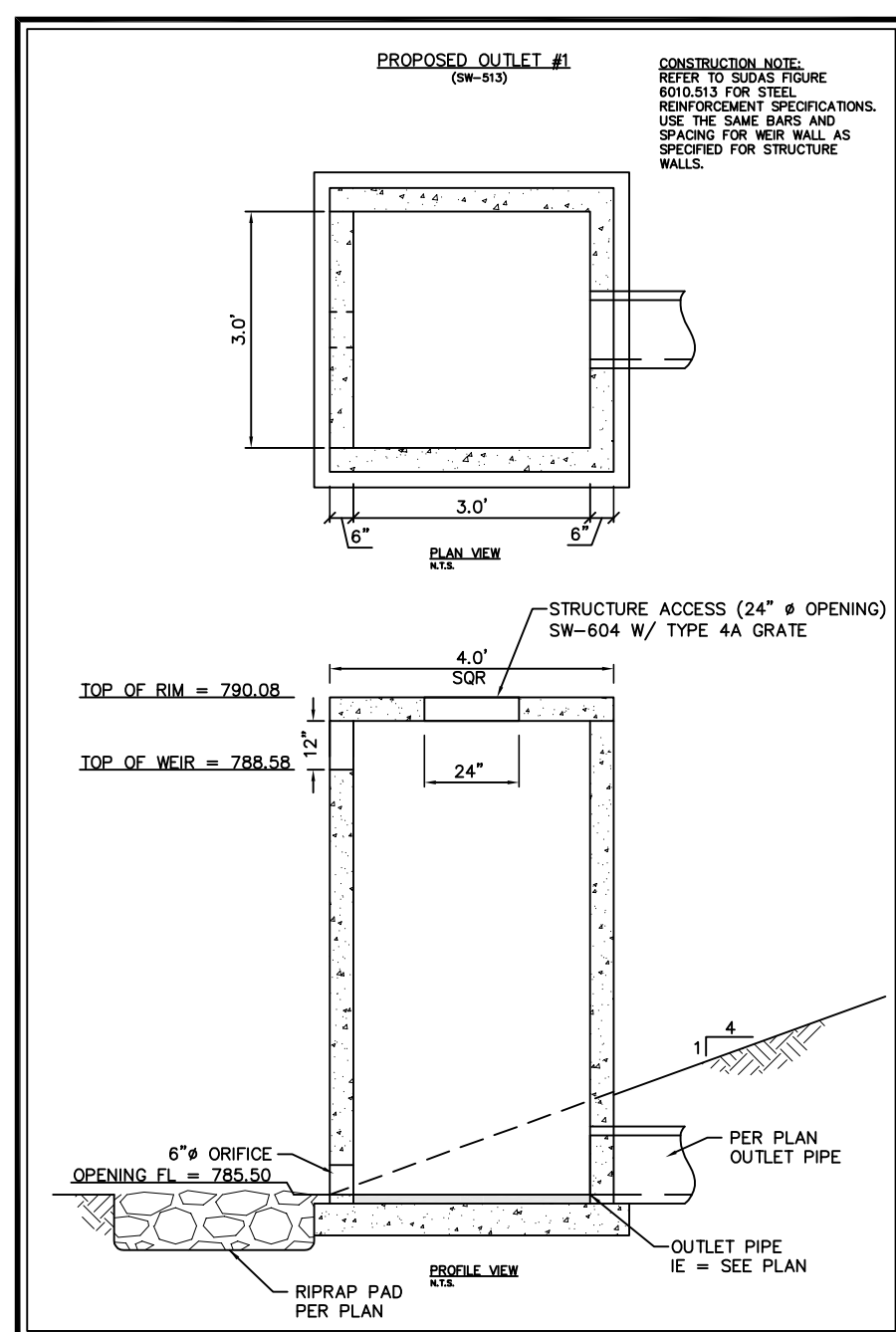

UTILITIES

THE CONTRACTOR SHALL NOTIFY IOWA ONE CALL NO LESS THAN 48 HRS. IN ADVANCE OF ANY DIGGING OR EXCAVATION.

WHERE PUBLIC UTILITY FIXTURES ARE SHOWN AS EXISTING ON THE PLANS OR ENCOUNTERED WITHIN THE CONSTRUCTION AREA, IT SHALL BE THE RESPONSIBILITY OF THE CONTRACTOR TO NOTIFY THE OWNERS OF THOSE UTILITIES PRIOR TO THE BEGINNING OF ANY CONSTRUCTION. THE CONTRACTOR SHALL AFFORD ACCESS TO THESE FACILITIES FOR NECESSARY MODIFICATION OF SERVICES. UNDERGROUND FACILITIES, STRUCTURES AND UTILITIES HAVE BEEN PLOTTED FROM AVAILABLE SURVEYS AND RECORDS, AND THEREFORE THEIR LOCATIONS MUST BE CONSIDERED APPROXIMATE ONLY. IT IS POSSIBLE THERE MAY BE OTHERS, THE EXISTENCE OF WHICH IS PRESENTLY NOT KNOWN OR SHOWN. IT IS THE CONTRACTOR'S RESPONSIBILITY TO DETERMINE THEIR EXISTENCE AND EXACT LOCATION AND TO AVOID DAMAGE THERE TO. NO CLAIMS FOR ADDITIONAL COMPENSATION WILL BE ALLOWED TO THE CONTRACTOR FOR ANY INTERFERENCE OR DELAY CAUSED BY SUCH WORK.

SHEET INDEX

1	SITE LAYOUT PLAN
2	SITE GRADING AND EROSION CONTROL PLAN
3	SITE UTILITY PLAN
4	SITE LANDSCAPE PLAN
5	GENERAL NOTES AND DETAILS

SITE UTILITY PLAN

LOGAN CONTRACTORS SUPPLY
LOT 2, RESUBDIVISION OF LOT 13,
I-380 INDUSTRIAL PARK
NORTH LIBERTY
JOHNSON COUNTY
IOWA

MMS CONSULTANTS, INC.

Date:	12-01-2016
Designed By:	BTM
Drawn By:	BTM
Checked By:	BTM
Project No:	IOWA CITY 6763011
Field Book No:	1053/59-62
Scale:	1"=30'
Sheet No:	3
of:	5

SITE PLAN

LOT 2, RESUBDIVISION OF LOT 13, I-380 INDUSTRIAL PARK

2755 STONER COURT NORTH LIBERTY, IOWA



CIVIL ENGINEERS
LAND PLANNERS
LAND SURVEYORS
LANDSCAPE ARCHITECTS
ENVIRONMENTAL SPECIALISTS

1917 S. GILBERT ST.
IOWA CITY, IOWA 52240
(319) 351-8282
www.mmsconsultants.net

Date	Revision
12-21-16	PER CITY COMMENTS - NPB
01-05-17	PER CITY COMMENTS - BTM

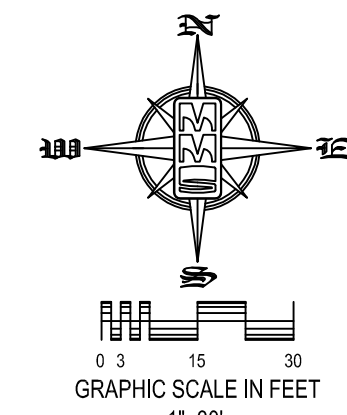

STANDARD LEGEND AND NOTES	
	PROPERTY &/or BOUNDARY LINES
	CONGRESSIONAL SECTION LINES
	RIGHT-OF-WAY LINES
	EXISTING CENTER LINES
	EXISTING RIGHT-OF-WAY LINES
	EXISTING CENTER LINES
	LOT LINES, INTERNAL
	LOT LINES, PLATTED OR BY DEED
	PROPOSED EASEMENT LINES
	EXISTING EASEMENT LINES
	BENCHMARK
	RECORDED DIMENSIONS
	CURVE SEGMENT NUMBER
	EXISTING TREE
	PROPOSED TREE
	EXISTING DEODUOUS TREE & SHRUB
	EXISTING EVERGREEN TREES & SHRUBS

THE ACTUAL SIZE AND LOCATION OF ALL PROPOSED FACILITIES SHALL BE VERIFIED WITH CONSTRUCTION DOCUMENTS, WHICH ARE TO BE PREPARED AND SUBMITTED SUBSEQUENT TO THE APPROVAL OF THIS DOCUMENT.

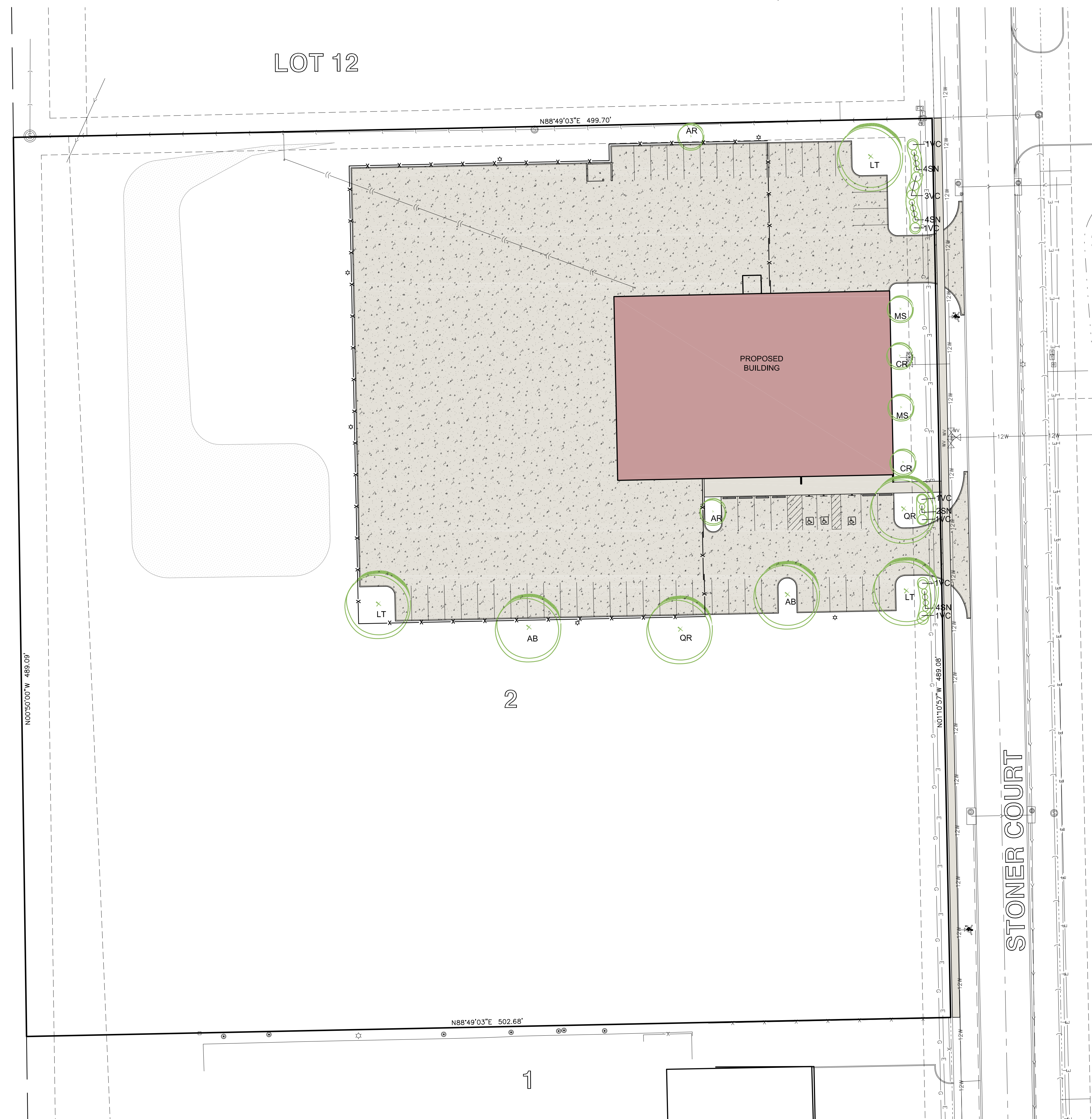

TREE REQUIREMENTS:
1 TREE / 2,000 SF BUILDING (BLDG)
BLDG = 15,000 SF = 8 TREES

1 TREE EVERY 40' FROM PARKING SPACE

31 TREES PROVIDED:
25 LARGE TREES
6 SMALL TREES

PLANT LIST - TREES						
QTY	KEY	BOTANICAL NAME	COMMON NAME	INSTALL SIZE	COMMENT	NATURE SIZE
27	AR	ACER * FREDERICK ASTORIAN BLAZE	ASTORIAN BLAZE RED MAPLE	1" CAL.	D & D	50' X 50'
12	AR	ACER RUBRA	RED SWAMP RED MAPLE	1" CAL.	D & D	50' X 50'
1	CR	CRATAEGUS CRUGSALLI INERMIS	THORNLESS COCKSPUR Hawthorn	1" CAL.	D & D	50' X 50'
1	LT	LIRIODENDRON TULIPIFERA	TULIPTREE	1" CAL.	D & D	80' X 50'
1	MS	MALUS SPINDS SNOW	SPRING SNOW CRABAPPLE	1 1/2" CAL.	D & D	5' X 5'
1	QR	QUERCUS RUBRA	RED OAK	1" CAL.	D & D	10' X 50'

PLANT LIST - SHRUBS, PERENNIALS, ORNAMENTAL GRASSES & GROUNDCOVER						
QTY	KEY	BOTANICAL NAME	COMMON NAME	INSTALL SIZE	COMMENT	NATURE SIZE
18	SN	SORGHASTRUM NITIVUM	INDIAN GRASS	18" HT.	CONT.	5' X 5'
9	VG	VERBENA TRILOBUM COMPACTA	COMPACT AMERICAN CRANBERRY BUSH VERBENA	14" HT.	CONT.	5' X 5'
9	WH	HAMAMELIS VERNALIS	WITCH HAZEL	14" HT.	CONT.	5' X 5'
10	VB	VERBENA VERONICA	ARBOREOUS VERBENA	14" HT.	CONT.	5' X 5'
12	RP	ROSTRALES COCCYDARIA ROYAL PURPLE	ROYAL PURPLE SANDERBUSH	14" HT.	CONT.	7' X 5'
11	PM	PRUNUS MURDO	MURDO PINE	14" HT.	CONT.	5' X 5'
10	JM	JUNIPERUS SCUTELLORUM MEDIOCA	MEDIOCA JUNIPER	14" HT.	CONT.	5' X 5'

URBAN AREAS PERMANENT SEED MIXTURE

URBAN AREAS SEEDING SHALL BE IN ACCORDANCE WITH I.D.O.T. STANDARD SPECIFICATION SECTION 2601.03 PERMANENT SEED MIXTURE, URBAN AREAS.

BLUEGRASS, KENTUCKY	70%
PERENNIAL RYEGRASS	10%
FESCUE, CREEPING RED	20%

UTILITIES

THE CONTRACTOR SHALL NOTIFY IOWA ONE CALL NO LESS THAN 48 HRS. IN ADVANCE OF ANY DIGGING OR EXCAVATION.

WHERE PUBLIC UTILITY FIXTURES ARE SHOWN AS EXISTING ON THE PLANS OR ENCOUNTERED WITHIN THE CONSTRUCTION AREA, IT SHALL BE THE RESPONSIBILITY OF THE CONTRACTOR TO NOTIFY THE OWNERS OF THOSE UTILITIES PRIOR TO THE BEGINNING OF ANY CONSTRUCTION. THE CONTRACTOR SHALL AFFORD ACCESS TO THESE FACILITIES FOR NECESSARY MODIFICATION OF SERVICES. UNDERGROUND FACILITIES, STRUCTURES AND UTILITIES HAVE BEEN PLOTTED FROM AVAILABLE SURVEYS AND RECORDS, AND THEREFORE THEIR LOCATIONS MUST BE CONSIDERED APPROXIMATE ONLY. IT IS POSSIBLE THERE MAY BE OTHERS, THE EXISTENCE OF WHICH IS PRESENTLY NOT KNOWN OR SHOWN. IT IS THE CONTRACTOR'S RESPONSIBILITY TO DETERMINE THEIR EXISTENCE AND EXACT LOCATION AND TO AVOID DAMAGE THERETO. NO CLAIMS FOR ADDITIONAL COMPENSATION WILL BE ALLOWED TO THE CONTRACTOR FOR ANY INTERFERENCE OR DELAY CAUSED BY SUCH WORK.

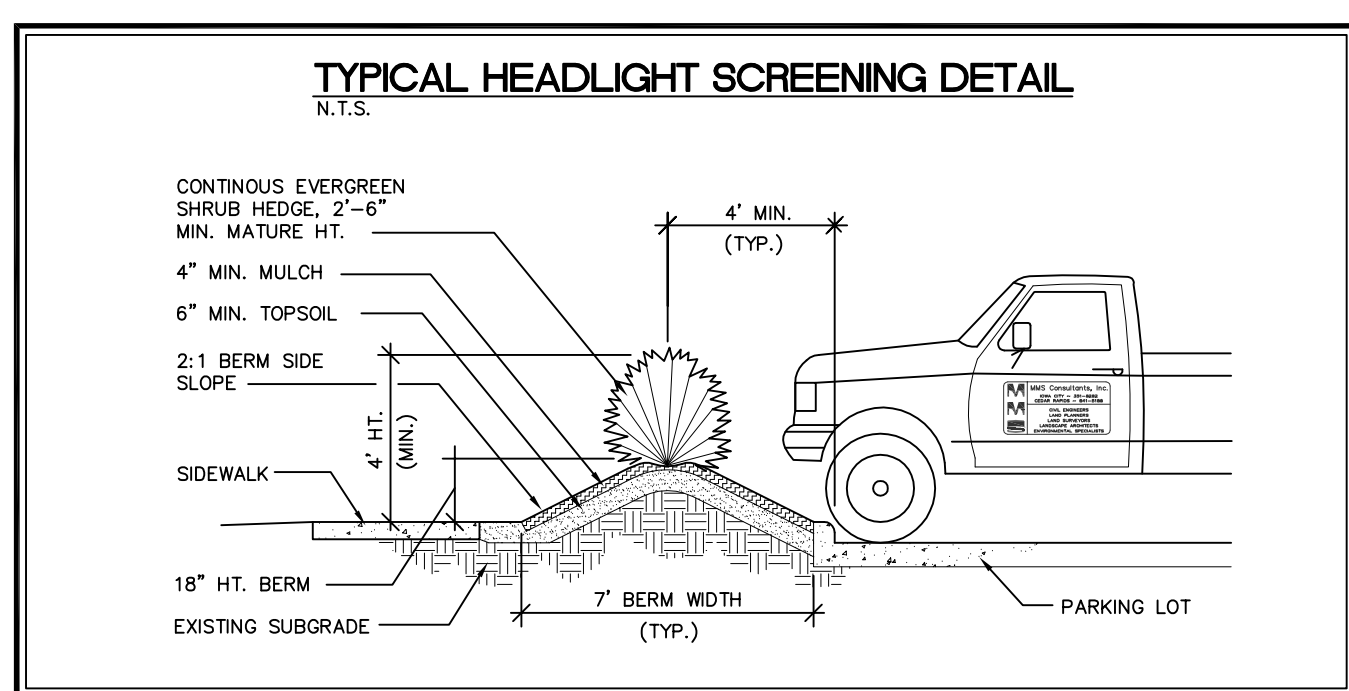

SHEET INDEX

1	SITE LAYOUT PLAN
2	SITE GRADING AND EROSION CONTROL PLAN
3	SITE UTILITY PLAN
4	SITE LANDSCAPE PLAN
5	GENERAL NOTES AND DETAILS

SITE LANDSCAPE PLAN

LOGAN CONTRACTORS SUPPLY
LOT 2, RESUBDIVISION OF LOT 13,
I-380 INDUSTRIAL PARK
NORTH LIBERTY
JOHNSON COUNTY
IOWA

MMS CONSULTANTS, INC.

Date:	12-01-2016
Designed By:	BTM
Field Book No.:	1053/59-62
Drawn By:	BTM
Scale:	1"=30'
Checked By:	BTM
Sheet No.:	4
Project No.:	IOWA CITY 6763011



CIVIL ENGINEERS
LAND PLANNERS
LAND SURVEYORS
LANDSCAPE ARCHITECTS
ENVIRONMENTAL SPECIALISTS

1917 S. GILBERT ST.
IOWA CITY, IOWA 52240
(319) 351-8282
www.mmsconsultants.net

Date	Revision
12-21-16	PER CITY COMMENTS - NPB
01-05-17	PER CITY COMMENTS - BTM

GENERAL NOTES AND DETAILS

LOGAN CONTRACTORS SUPPLY
LOT 2, RESUBDIVISION OF LOT 13,
I-380 INDUSTRIAL PARK
NORTH LIBERTY
JOHNSON COUNTY
IOWA

MMS CONSULTANTS, INC.

Date:	12-01-2016
Designed By:	BTM
Drawn By:	BTM
Checked By:	BTM
Project No:	IOWA CITY 6763011
Field Book No:	1053/59-62
Scale:	
Sheet No:	5
of:	5

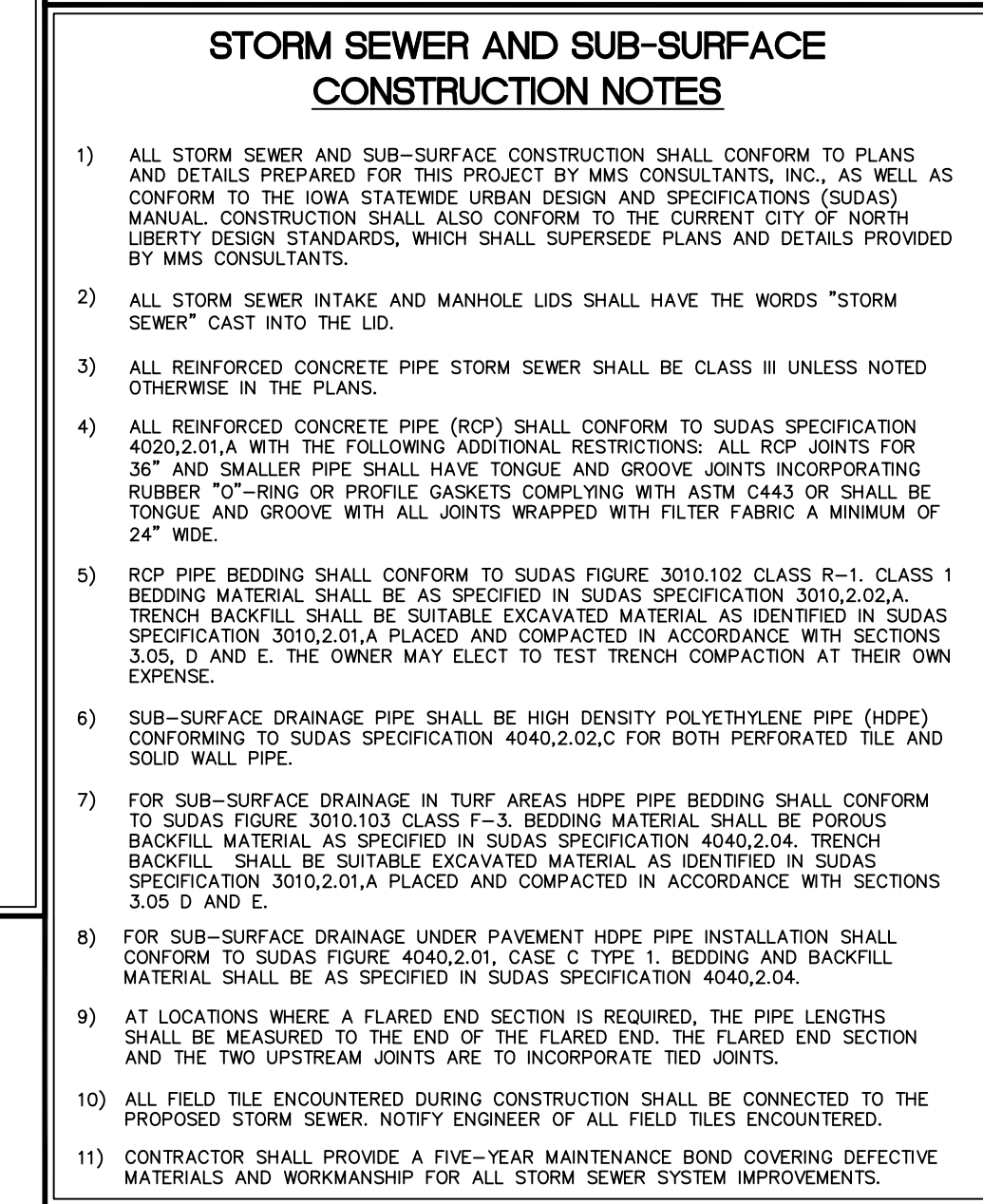
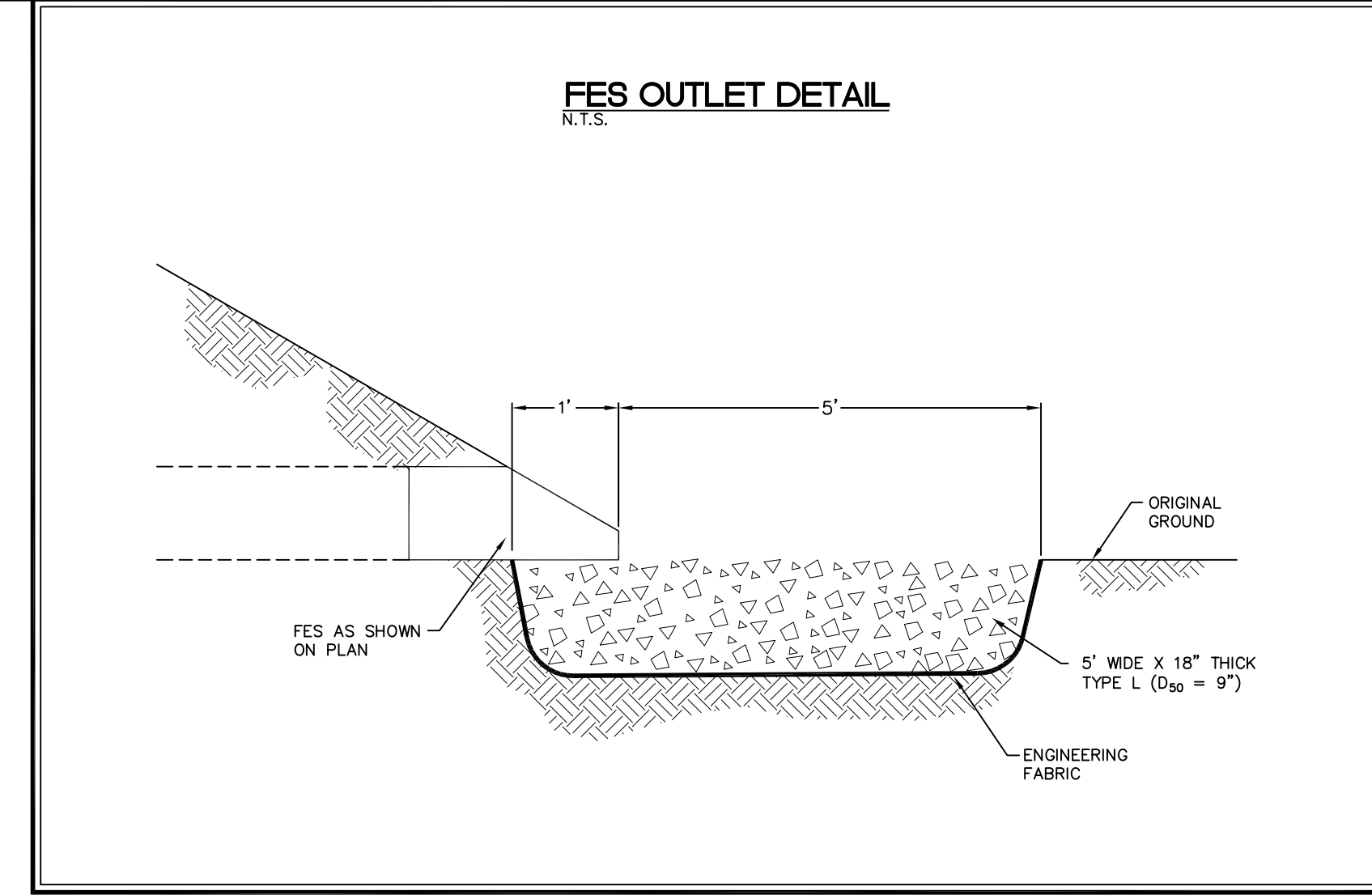
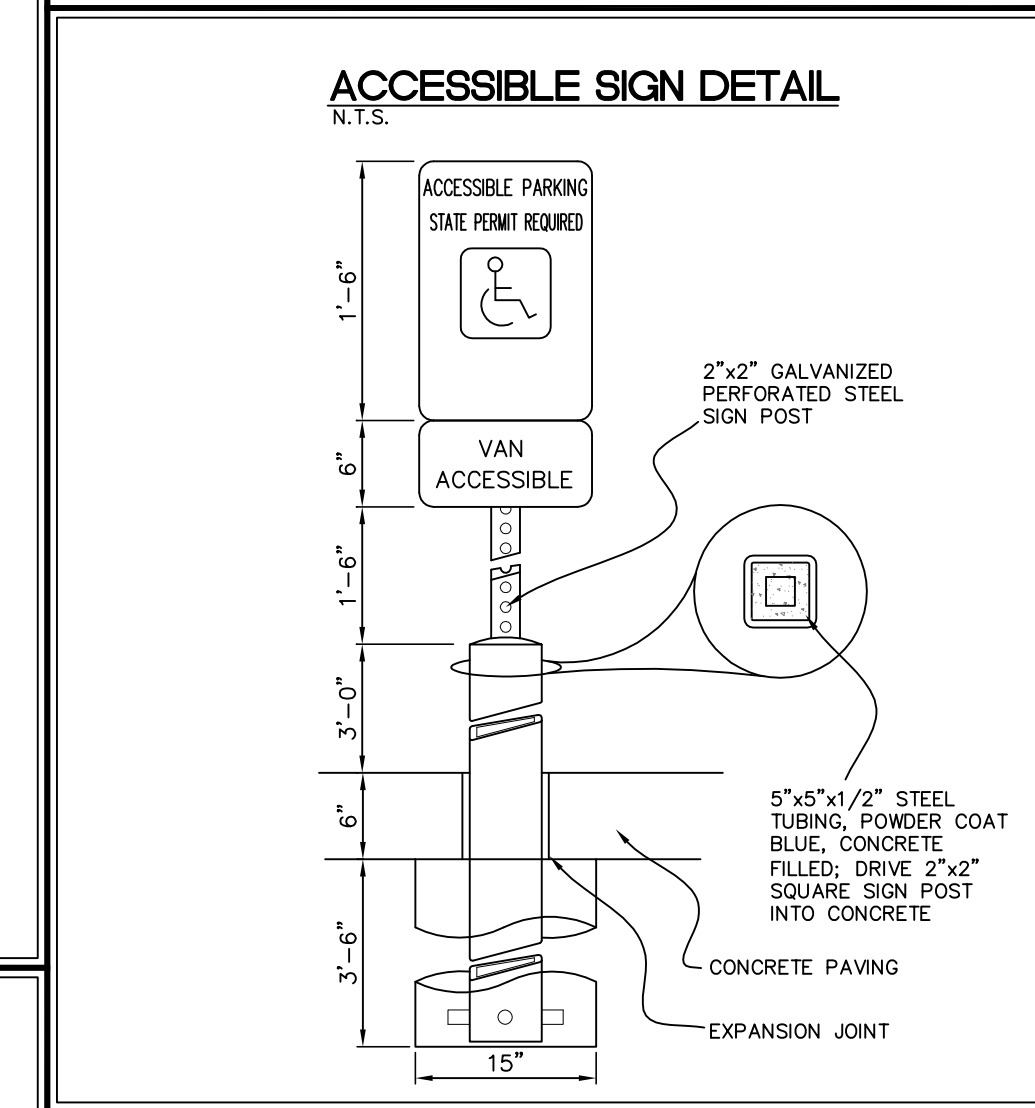
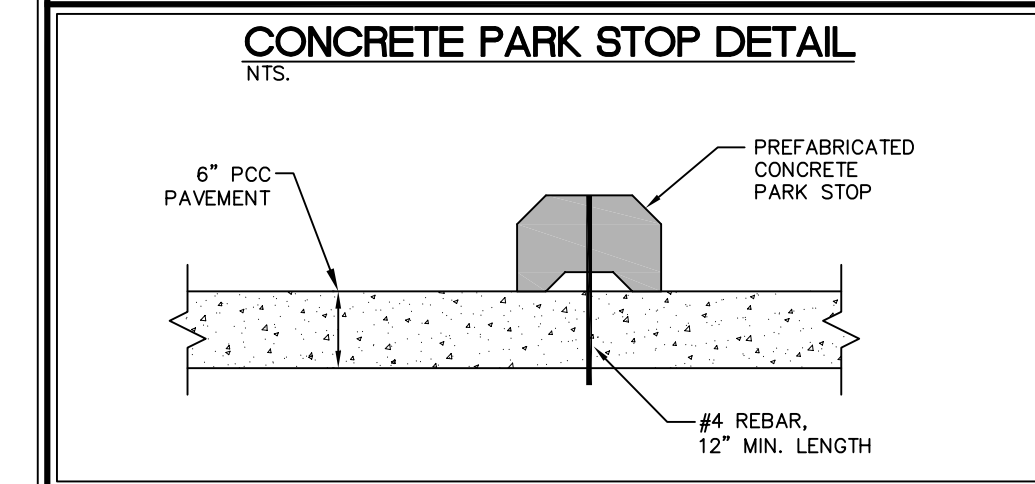
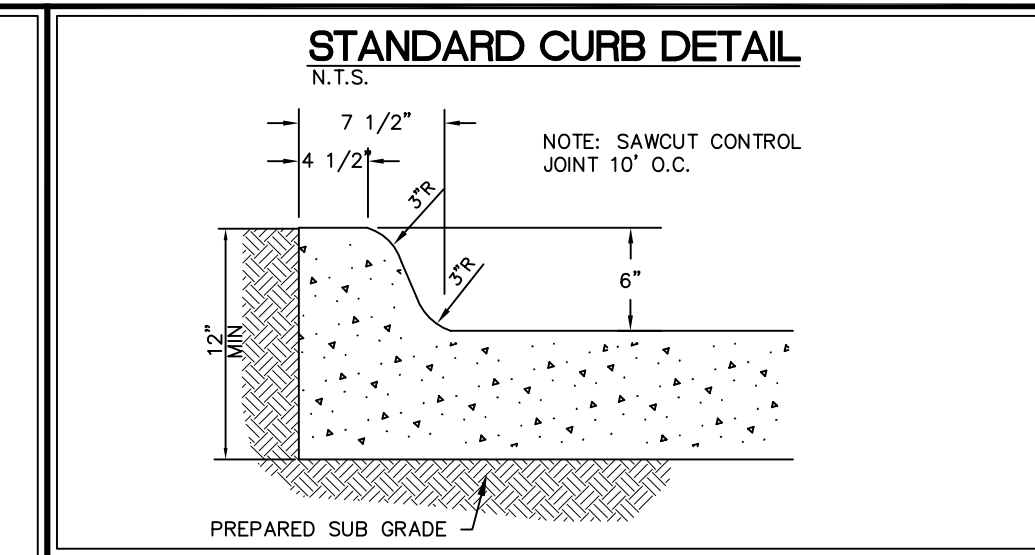
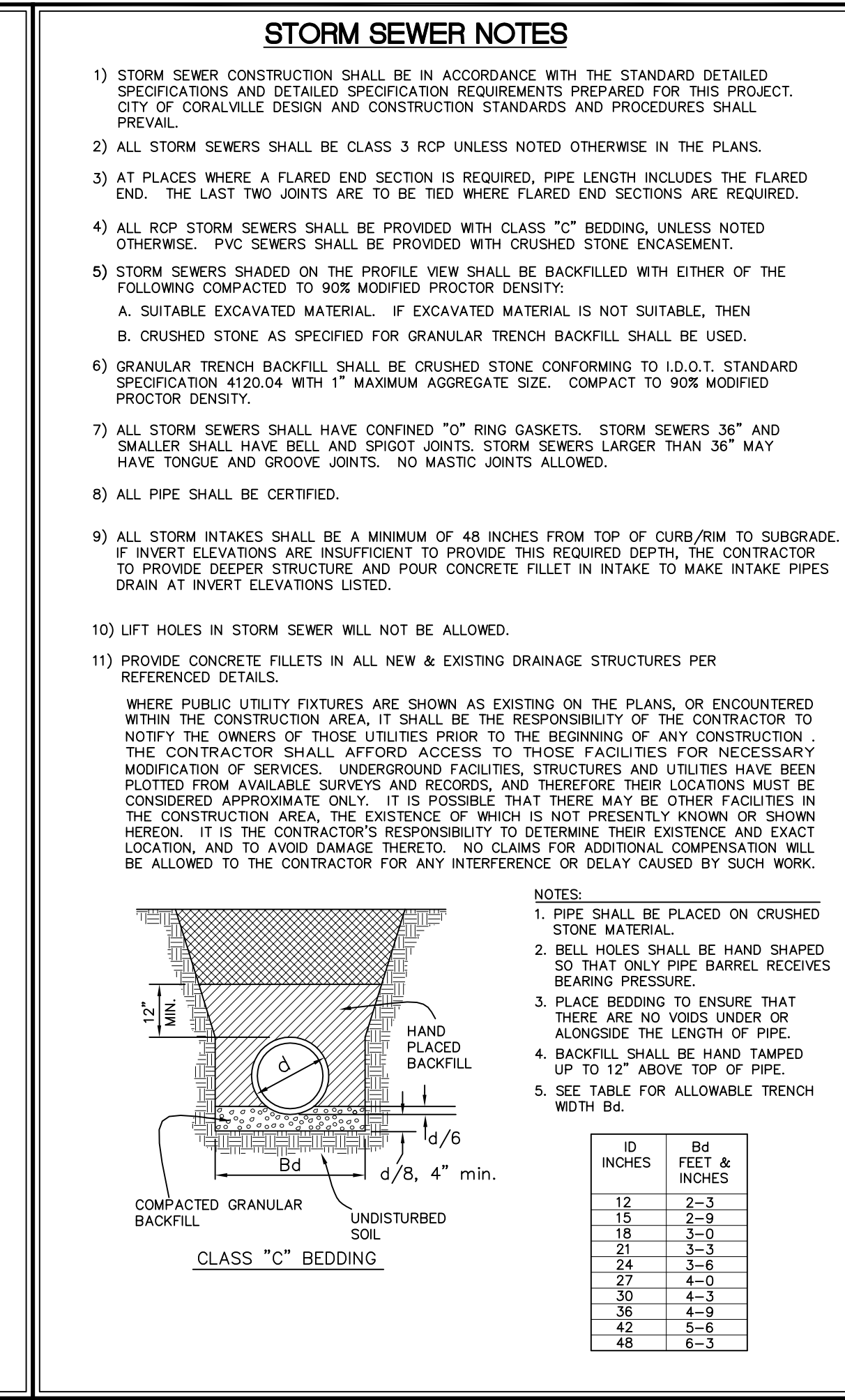
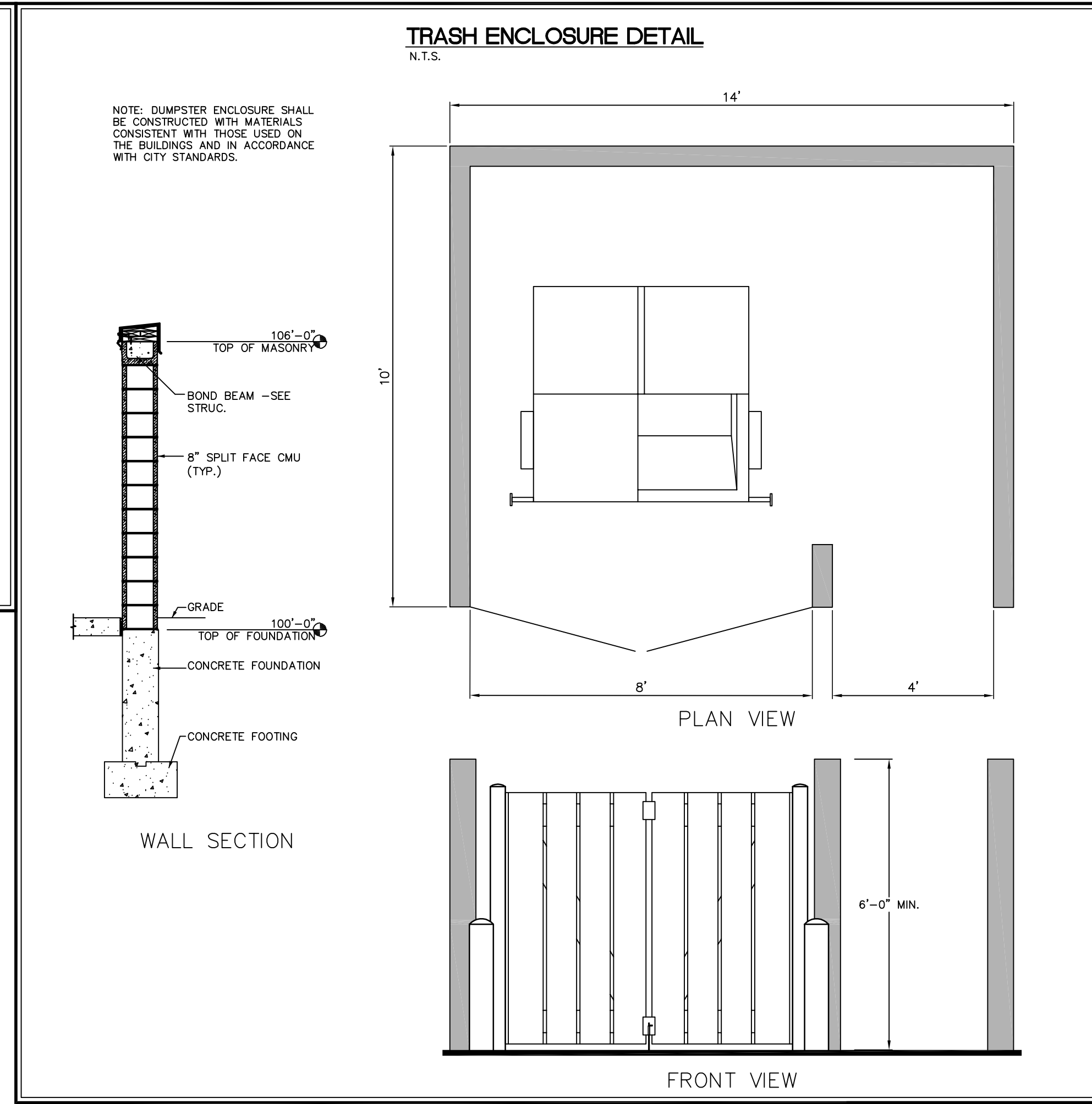
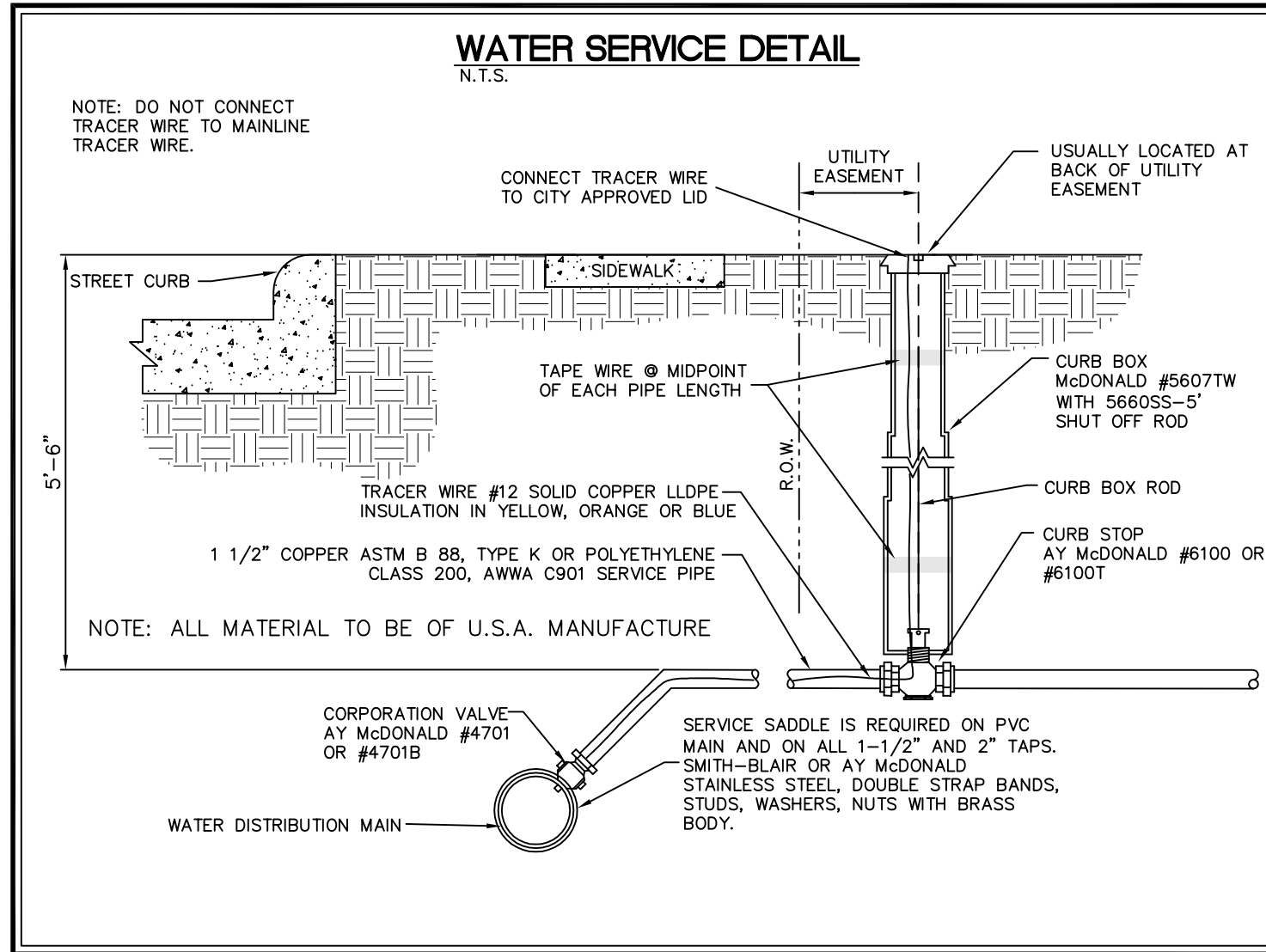

SHEET INDEX

- 1 SITE LAYOUT PLAN
- 2 SITE GRADING AND EROSION CONTROL PLAN
- 3 SITE UTILITY PLAN
- 4 SITE LANDSCAPE PLAN
- 5 GENERAL NOTES AND DETAILS

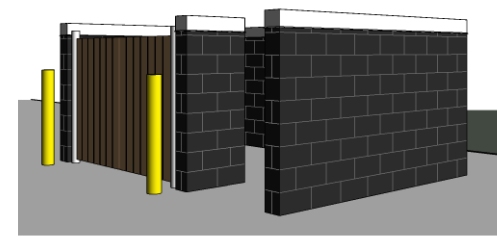

10 DUMPSTER PERSPECTIVE

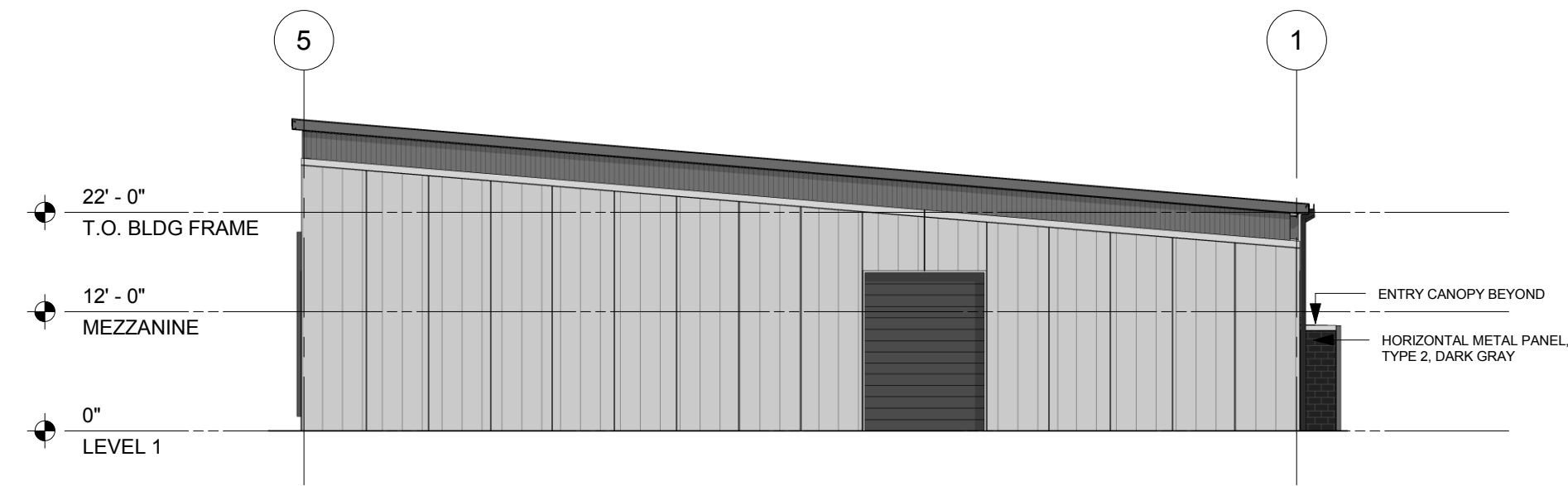

6 WEST ELEVATION
1/16" = 1'-0"

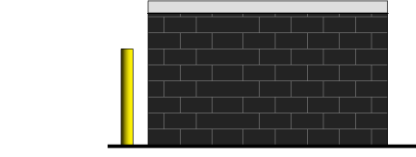

9 DUMPSTER ENCLOSURE SIDE
1/8" = 1'-0"

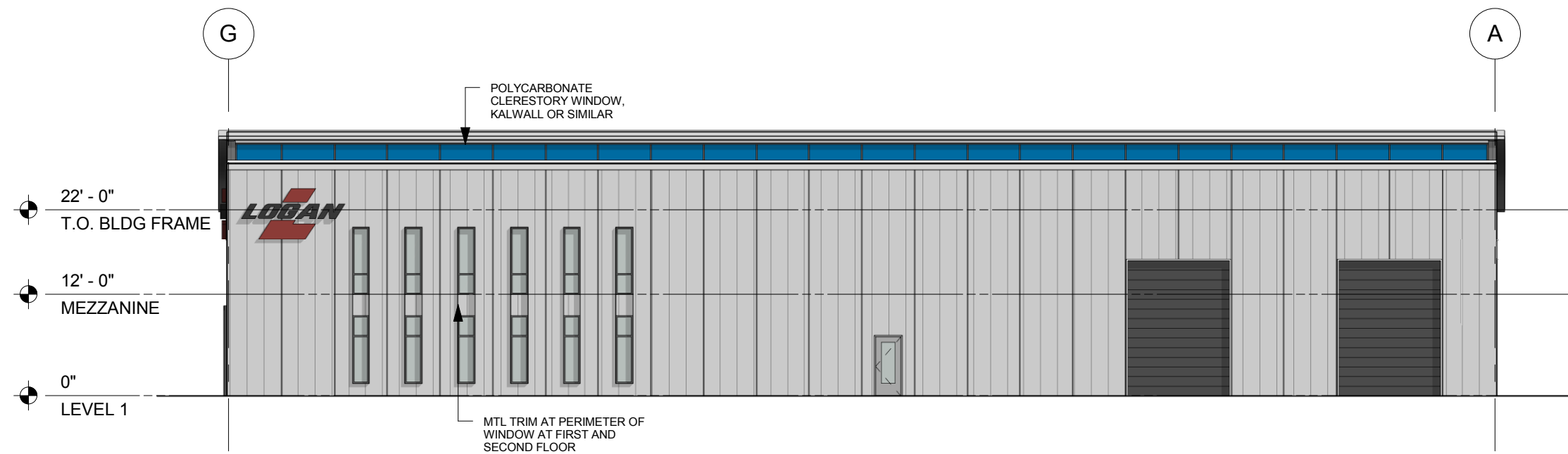

5 NORTH ELEVATION
1/16" = 1'-0"

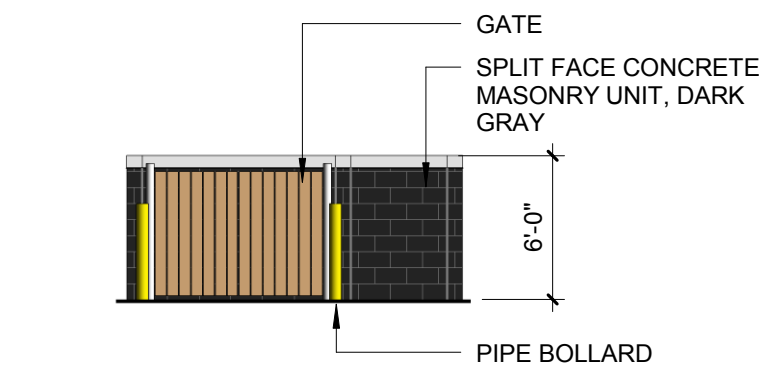

8 DUMPSTER ENCLOSURE FRONT
1/8" = 1'-0"

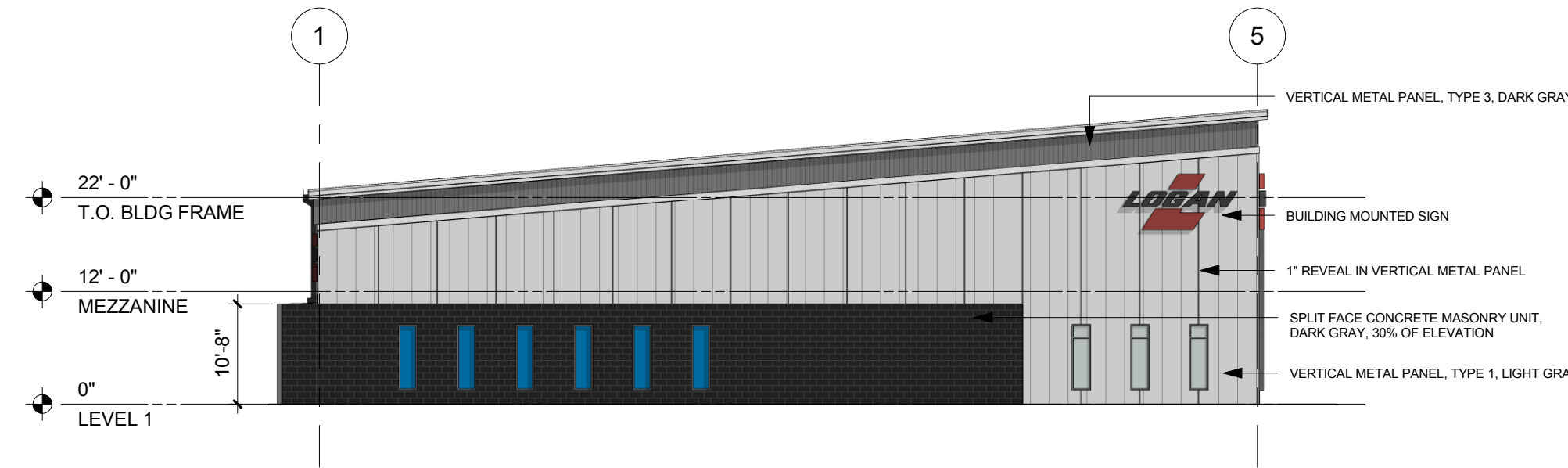

4 EAST ELEVATION - FACES STONER COURT
1/16" = 1'-0"

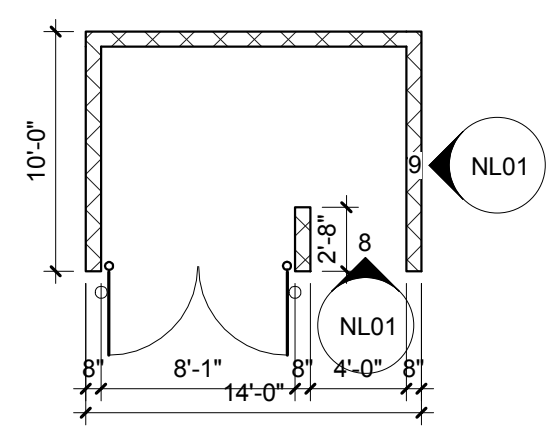

7 FIRST FLOOR PLAN

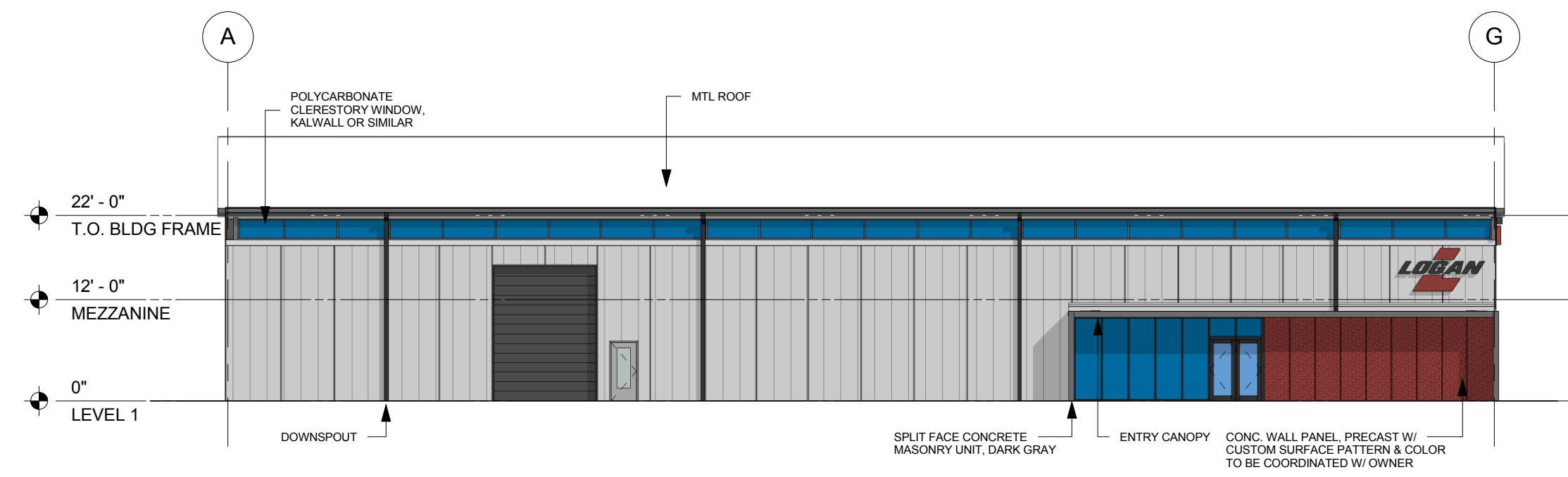

3 SOUTH ELEVATION
1/16" = 1'-0"

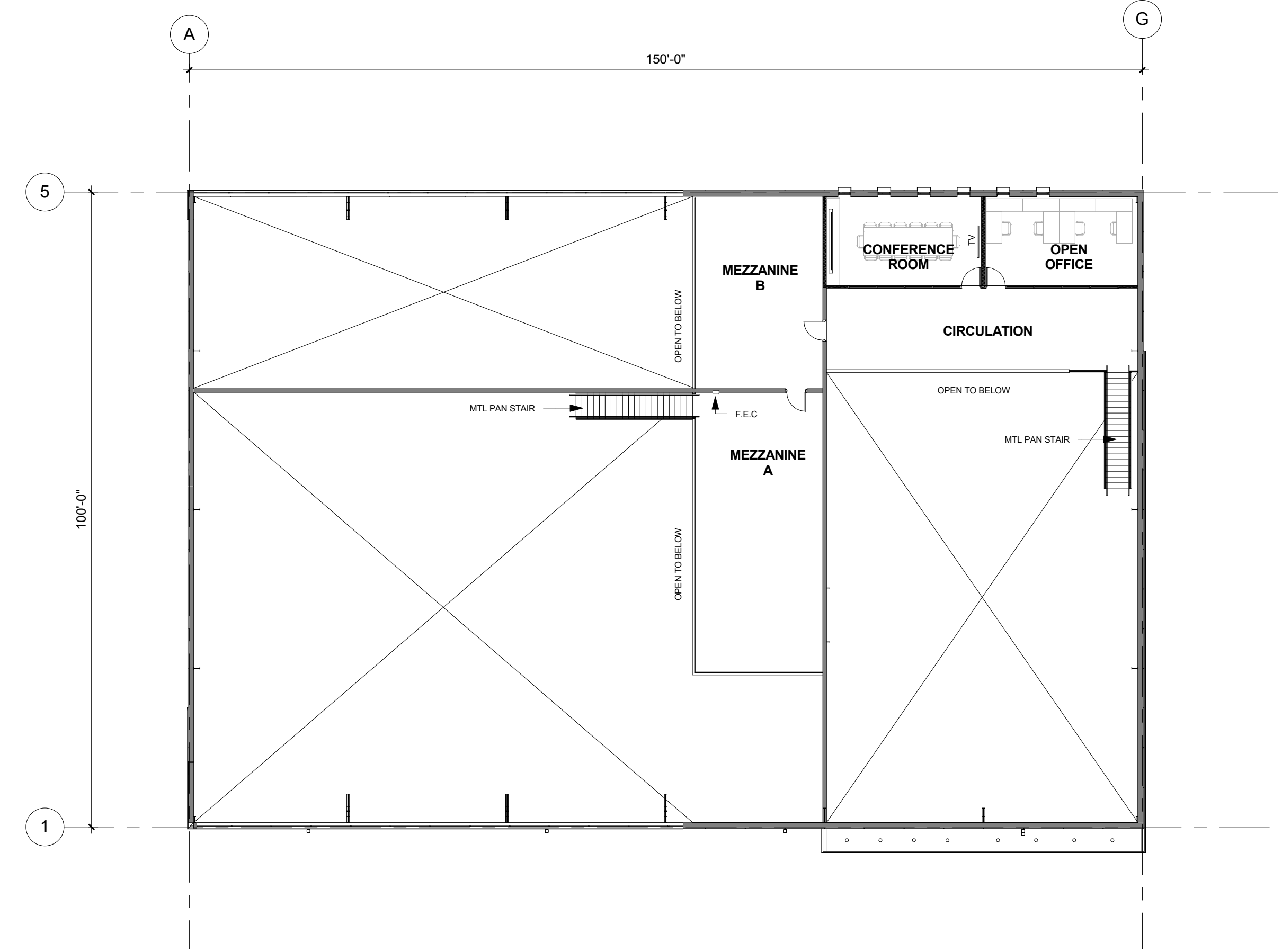

2 SUBMITTAL MEZZANINE PLAN
1/16" = 1'-0"

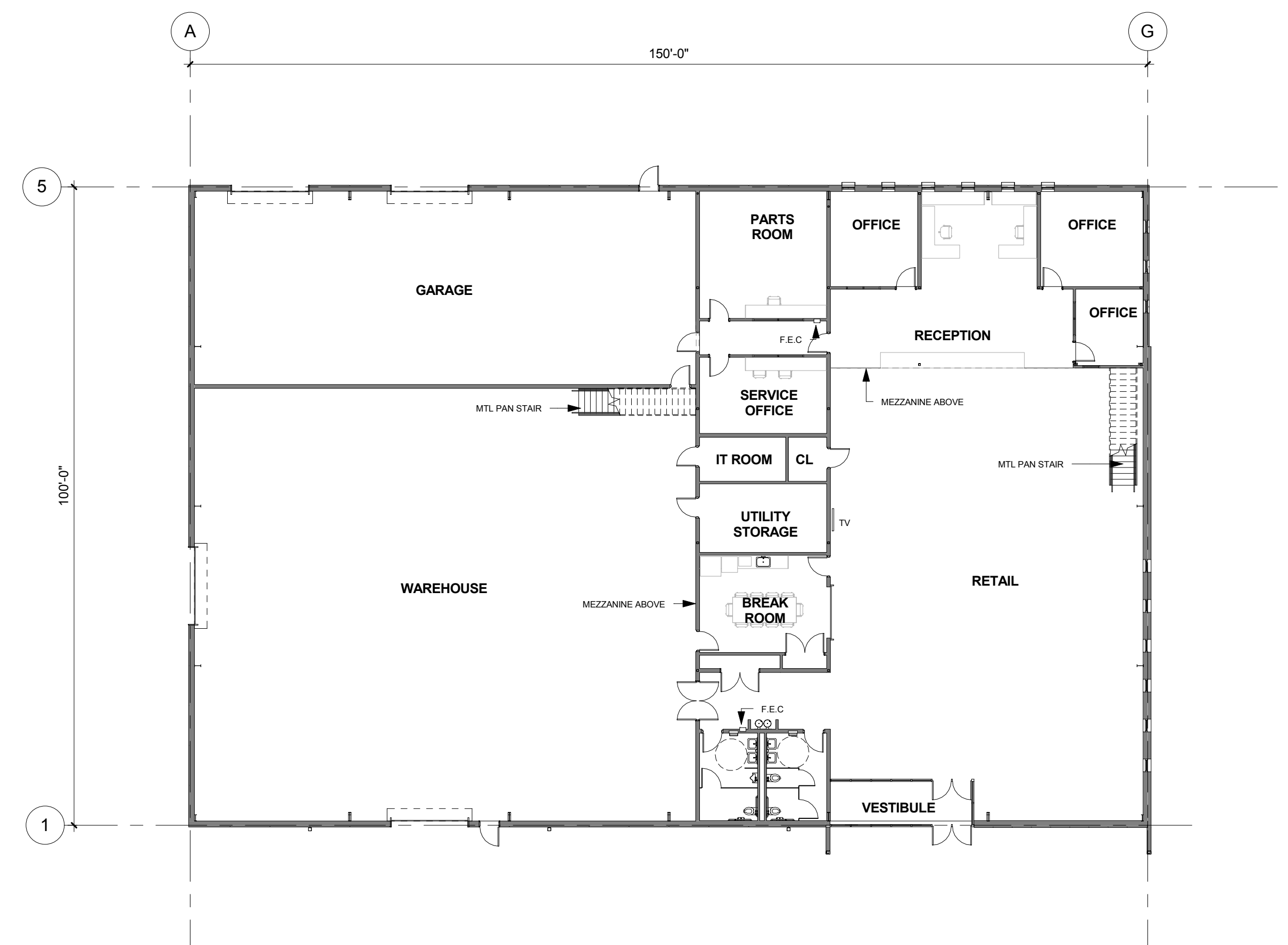

1 FIRST FLOOR PLAN
1/16" = 1'-0"



3 NORTH-EAST CORNER



4 NORTH-WEST CORNER



2 SOUTH-WEST CORNER

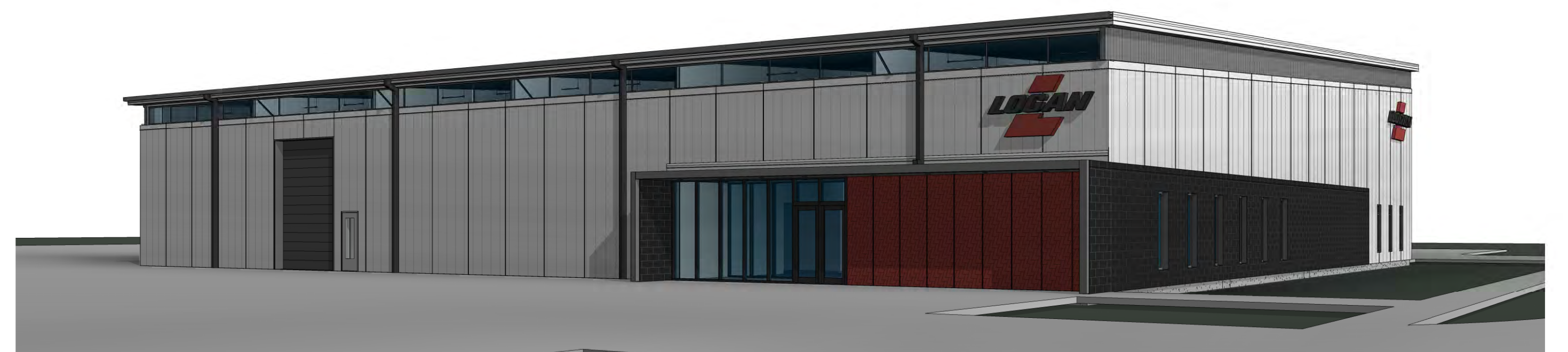

1 SOUTH-EAST CORNER

Resolution No. 2017-07

**RESOLUTION APPROVING THE DEVELOPMENT SITE PLAN
FOR LOT 2, RESUBDIVISION OF LOT 13, I-380 INDUSTRIAL
PARK, NORTH LIBERTY, IOWA**

**BE IT RESOLVED BY THE CITY COUNCIL OF THE CITY OF NORTH LIBERTY,
IOWA:**

WHEREAS, the owner, Logan Contractor Supply, has filed with the City Clerk a development site plan;

WHEREAS, the property is legally described as:

Lot 2, Resubdivision of Lot 13, I-380 Industrial Park, North Liberty, Iowa,
according to the plat thereof recorded in Book 49, Page 61, Plat Records of
Johnson County, Iowa;

WHEREAS, said site plan is found to conform with the Comprehensive Plan and the Zoning Ordinance of the City of North Liberty; and

WHEREAS, said site plan has been examined by the North Liberty Planning and Zoning Commission, which recommended that the site plan be approved.

NOW, THEREFORE, BE IT RESOLVED that the City Council of North Liberty, Iowa, does hereby approve the development site plan for Logan Contractor Supply, North Liberty, Iowa.

APPROVED AND ADOPTED this 24th day of January, 2017.

CITY OF NORTH LIBERTY:

ATTEST:

TERRY L. DONAHUE, MAYOR PRO TEM

TRACEY MULCAHEY, CITY CLERK

Parking Resolution

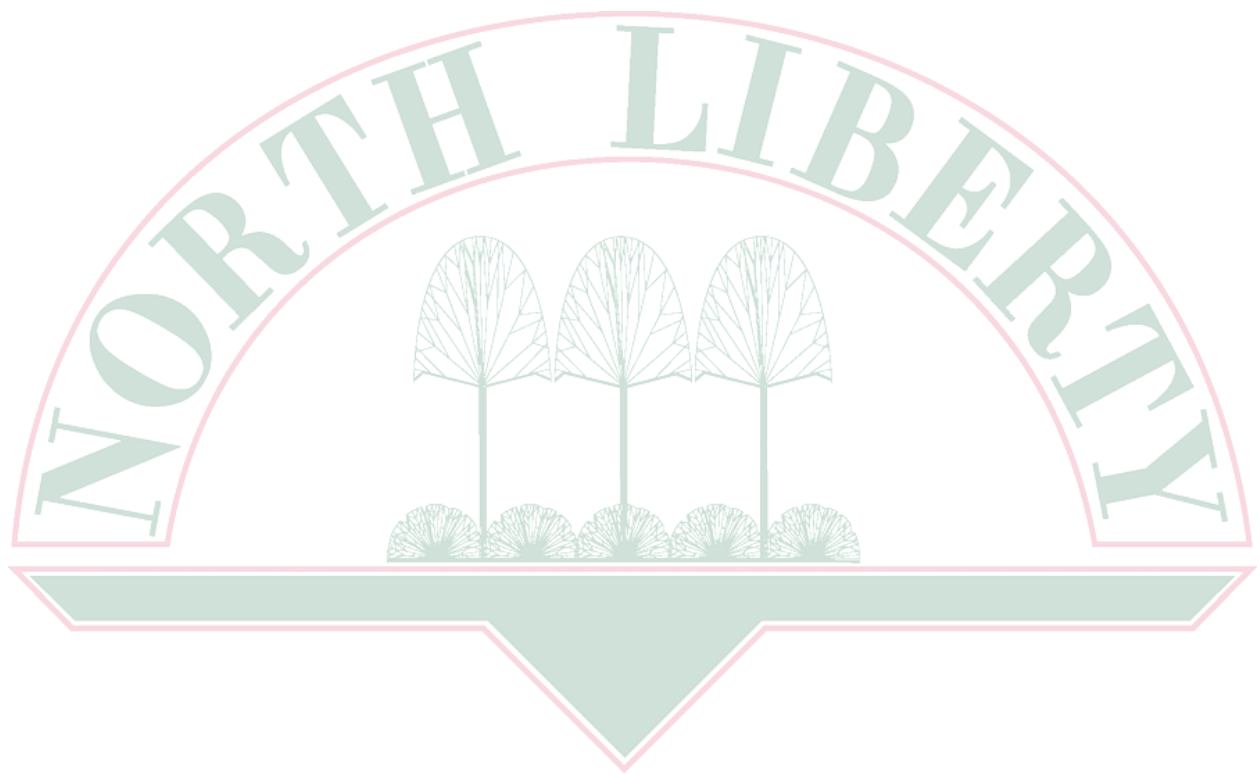

Resolution No. 2017-08

A RESOLUTION APPROVING PARKING CONTROL DEVICES IN THE CITY OF NORTH LIBERTY, IOWA

WHEREAS, Section 69.08 of the North Liberty Code of Ordinances authorizes the City Council to establish by resolution and cause to be placed parking control devices that prohibit or limit parking at designated locations in accordance with Chapter 69 of the City's Code; and

WHEREAS, the City Council has previously prohibited or limited parking throughout the City and has now reviewed the same.

BE IT THEREFORE NOW RESOLVED BY THE CITY COUNCIL OF NORTH LIBERTY, IOWA, that the City of North Liberty, Iowa, hereby establishes the placement of parking control devices to prohibit or limit parking for the City's street system as follows:

- No person, except persons on medical emergency calls, shall park a vehicle on any street designated to prohibit all-night parking for period of time longer than thirty minutes between the hours of 2:00 a.m. and 5:00 a.m. No person, except persons on medical emergency calls, shall park a vehicle on any street marked to prohibit parking during any other specified period for a period of time longer than fifteen minutes during the hours for which parking is prohibited on said street.
- Parking on Zeller Street will be prohibited on the north side of the street on even-numbered days between the hours of 6:00 a.m. and 6:00 p.m. and will be prohibited on the south side of the street on odd-numbered days between the hours of 6:00 a.m. and 6:00 p.m.
- Parking is prohibited at all times on both sides of Juniper Court from Hackberry Street to Juniper Street.
- Parking is prohibited on Heritage Place on the north side of the street on even-numbered days between the hours of 6:00 a.m. and 6:00 p.m. and on the south side of the street on odd-numbered days between the hours of 6:00 a.m. and 6:00 p.m.
- Parking is prohibited at all times on both sides of Jones Boulevard.
- Parking is prohibited at all times on the north side of Dickinson Drive from Dubuque Street east to the intersection with Whitman Avenue.
- Parking is prohibited on the east side of Mark Twain Court abutting Lots 14 and 16 on even-numbered days between the hours of 6:00 a.m. and 6:00 p.m. and on the south and west side of said street abutting Lots 13 through 19 on odd-numbered days between the hours of 6:00 a.m. and 6:00 p.m.
- Parking is prohibited at all times on both sides of Front Street from Dubuque Street north to the city limits.
- Parking is prohibited on the east side of Front Street between Cherry Street south to Zeller Street on even-numbered days between the hours of 6:00 a.m. and 6:00 p.m. and on the west side of Front Street between Cherry Street south to Zeller Street on odd-numbered days between the hours of 6:00 a.m. and 6:00 p.m.

- Parking is prohibited at all times on both sides of Front Street from Zeller Street south to the city limits.
- Parking is prohibited at all times on both sides of Penn Street.
- Parking is prohibited at all times on the north and east sides of Prairie Ridge Road between Sugar Creek Lane and Zeller Street and is also prohibited on the south side of Prairie Ridge Road from a point one hundred eighty-five feet west of the intersection with Sugar Creek Lane east to the intersection with Sugar Creek Lane.
- Parking is prohibited at all times on both sides of Sugar Creek Lane from Zeller Street south to the intersection with Fairview Lane, except that parking is permitted on the east side of Sugar Creek Lane from Westwood Drive to Fairview Lane.
- Parking is prohibited at all times on both sides of Hawkeye Drive between Highway 965 and Spartan Drive.
- Parking is prohibited at all times on both sides of Westwood Drive.
- Parking is prohibited at all times on both sides of Dubuque Street from Main Street north to the city limits; and from a point one hundred feet south of the intersection with Cherry Street south to the city limits.
- Parking is prohibited at all times on both sides of Liberty Way.
- Parking is prohibited at all times on both sides of Cherry Street from the CRANDIC railroad crossing west to the intersection of Highway 965, and on the south side of Cherry Street west from Highway 965 to its westerly termination.
- Parking is prohibited at all times on the east side of Emily Street and on the cul de sac.
- Parking is prohibited at all times on the east side of Hodge Street.
- Parking is prohibited at all times on the west side of Jessie Street and anywhere on the two extensions on the east side and west side of Jessie Street.
- Parking is prohibited at all times on the east side of Molly Street.
- Parking on the north side of East Hickory Street is prohibited at all times in sections between posted signs, and on the south side of East Hickory Street where posted at the inside corner approximately two hundred feet east of Front Street.
- Parking is prohibited at all times on the west side of Park View Court from the intersection of Zeller Street to a point five hundred feet south.
- Parking is prohibited at all times on the east side of North Stewart from the intersection of Penn Street to a point three hundred feet south.
- Parking is prohibited at all times on the side of Elm Ridge Drive adjacent to the properties with even-numbered addresses.
- Parking is prohibited at all times on the side of Elm Ridge Court adjacent to the properties with odd-numbered addresses.
- Parking is prohibited at all times on the side of Hawthorne Place adjacent to the properties with odd-numbered addresses.
- Parking is prohibited at all times on the side of Maple Street adjacent to properties with even-numbered addresses.
- Parking is prohibited at all times on both sides of Lions Drive.
- Parking is prohibited at all times on both sides of Hawkeye Drive.
- Parking is prohibited at all times on both sides of Commercial Drive.
- Parking is prohibited at all times on both sides of Progress Street.

- Parking is prohibited at all times on both sides of 240th Street.
- Parking is prohibited at all times on both sides of Kansas Avenue.
- Parking is prohibited at all times on both sides of Alexander Way.
- Parking is prohibited at all times on both sides of Herky Street from its intersection with Penn Street south a distance of nine hundred and ten feet.
- Parking is prohibited at all times on both sides of Stoner Court.
- Parking is prohibited at all times on both sides of Community Drive.
- Parking is prohibited at all times on both sides of Lininger Lane.
- Parking is prohibited at all times on both sides of Penn Court on both the North and West parts of the street.
- Parking is prohibited at all times on the south side of Devmont Court.
- Parking is prohibited at all times on the south side of East Jefferson Street.
- Parking is prohibited at all times on the south side of Juniper Street.
- Parking is prohibited at all times on the north side of Hackberry Street.
- Parking is prohibited at all times on both sides of Highway 965.
- Parking is prohibited at all times on the west side of Main Street.
- Parking is prohibited at all times on the south side of 236th Street between Progress Street and North Jones Boulevard and on the north side of 236th Street from Progress Street to the west 140 feet.
- Parking is prohibited at all times on both sides of 238th Street between Progress Street and North Jones Boulevard.
- Parking is prohibited on both sides of Vandello Drive between Front Street and Cook Circle; on the north side of Vandello Drive between Cook Circle and Sadler Drive; and on both sides of Vandello 60 feet from its intersection with Sadler Drive.
- Parking is prohibited on the west side of Cook Circle.
- Parking is prohibited on the south side of Pheasant Lane from Scales Bend Road to Highway 965.
- Parking is prohibited on the north side of Pheasant Lane from Scales Bend Road to Timber Wolf Drive through the duration of the Highway 965 Project.
- Parking is prohibited on Birch Street, from Front Street west approximately 320 feet to the first Stewart Street intersection.
- Parking is prohibited on the west side of Rachael Street from the intersection of Blue Sky Drive to the south to the end of the street.
- ***Parking is prohibited on the south side of Ashley Court from the intersection with Highway 965 to the eastern end, at the railroad property.***

APPROVED AND ADOPTED this 24th day of January, 2017.

CITY OF NORTH LIBERTY:

ATTEST:

TERRY L. DONAHUE, MAYOR PRO TEM

TRACEY MULCAHEY, CITY CLERK

North Liberty Cafeteria Plan



AMENDMENT

To the
City of North Liberty Cafeteria Plan

Effective for Plan Years
Beginning on or After January 1, 2017

AMENDMENT

To the
City of North Liberty Cafeteria Plan

Effective for Plan Years
Beginning On or After January 1, 2017

The Sections of the Plan specified below shall be amended by addition or deletion and substitution:

ARTICLE VII. HEALTH FSA COMPONENT

7.4 Maximum and Minimum Benefits

- (a) *Maximum Reimbursement Available; Uniform Coverage.* The maximum dollar amount elected by the Participant for reimbursement of Medical Care Expenses incurred during a Period of Coverage (reduced by prior reimbursements during the Period of Coverage) shall be available at all times during the Period of Coverage, regardless of the actual amounts credited to the Participant's Health FSA Account pursuant to Section 7.5. Notwithstanding the foregoing, no reimbursements will be available for Medical Care Expenses incurred after coverage under this Plan has terminated, unless the Participant has elected COBRA as provided in Section 7.8. Payment shall be made to the Participant in cash as reimbursement for Medical Care Expenses incurred during the Period of Coverage for which the Participant's election is effective, provided that the other requirements of this Article VII have been satisfied.
- (b) *Maximum and Minimum Dollar Limits.* The maximum annual benefit amount that a Participant may elect to receive under this Plan in the form of reimbursements for Medical Care Expenses incurred in any Period of Coverage shall be limited only by the limitations on contributions found in Paragraph 4 of Section 5.3, increased by the amount of carry over provided under Section 7.6, if applicable. If a Participant elects to receive reimbursements for Medical Care Expenses, the minimum annual benefit amount that a Participant may elect to receive under this Plan in the form of reimbursements for Medical Care Expenses incurred in any Period of Coverage shall be \$30.00.
- (c) *Changes; No Proration.* For subsequent Plan Years, the maximum and minimum dollar limit may be changed by the Plan Administrator and shall be communicated to Employees through the Election Form/Salary Reduction Agreement or another document. If a Participant enters the Health FSA Component mid-year, or wishes to increase his or her election mid-year as permitted under Section 12.4, there will be no proration rule—i.e., the Participant may elect coverage up to the maximum dollar limit or may increase coverage to the maximum dollar limit, as applicable.
- (d) *Effect on Maximum Benefits If Election Change Permitted.* Any change in an election under Article XII affecting annual Contributions to the Health FSA Component also will change the maximum reimbursement benefits for the balance of the Period of Coverage commencing with the election change. Such maximum reimbursement benefits for the balance of the Period of Coverage shall be calculated by adding (1) the Contributions made by the Participant (if any) as of the end of the portion of the Period of Coverage immediately preceding the change in election, to (2) the total Contributions scheduled to be made by the Participant during the remainder of such Period of Coverage to the Health FSA Account, reduced by (3) all reimbursements made during the entire Period of Coverage.

This amendment is hereby executed on this _____ day of _____, 20____ under the authority granted under Section 15.3 of the Plan Document.

City of North Liberty

By: _____

Resolution No. 2017-09

**RESOLUTION APPROVING THE AMENDED CAFETERIA
PLAN FOR EMPLOYEES IN THE CITY OF NORTH LIBERTY,
IOWA**

**BE IT RESOLVED BY THE CITY COUNCIL OF THE CITY OF NORTH LIBERTY,
IOWA:**

WHEREAS, the City of North Liberty approved a contract and Agreement with Advantage Administrators on April 24, 2012;

WHEREAS, an amendment is necessary to the previously approved cafeteria plan and

WHEREAS, the amendment is that the North Liberty Cafeteria Plan effective for plan years beginning on or after January 1, 2017 is amended to increase the maximum Health Flexible Spending Account annual benefit limit.

NOW, THEREFORE, BE IT RESOLVED that the City Council of North Liberty, Iowa, does hereby approve the amendment to the North Liberty Cafeteria Plan and hereby authorizes the Mayor or other authorized individual to execute the amended plan.

APPROVED AND ADOPTED this 24th day of January, 2017.

CITY OF NORTH LIBERTY:

ATTEST:

TERRY L. DONAHUE, MAYOR PRO TEM

TRACEY MULCAHEY, CITY CLERK

Mayoral Vacancy

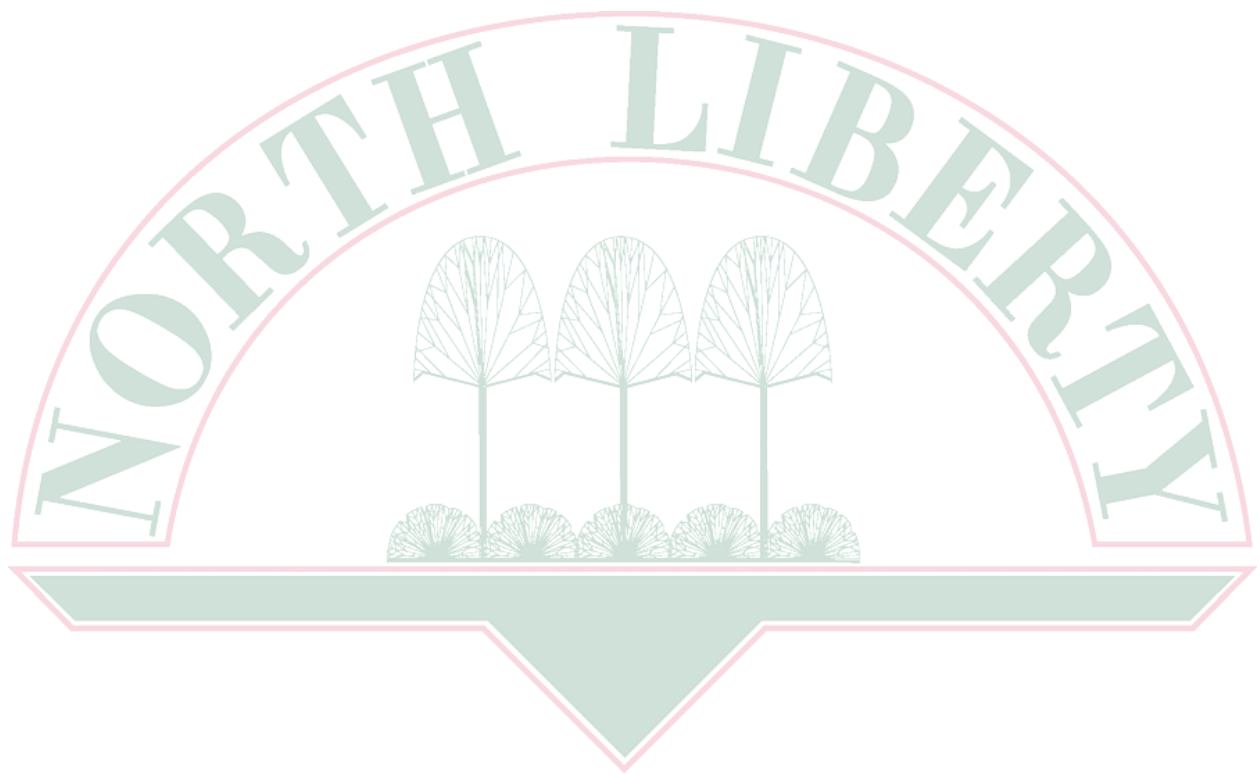

Tracey Mulcahey

From: Scott Peterson
Sent: Thursday, January 05, 2017 5:09 PM
To: Annie Pollock; Brian Wayson; Alert Chris Hoffman; Terry Donahue; Jim Sayre; Annie (Obrecht) Pollock (annie-pollock@uiowa.edu)
Cc: Tracey Mulcahey; Ryan Heiar
Subject: RE: Another update re mayoral vacancy

All:

As I mentioned to you at the last meeting, I will be out of state next Tuesday and therefore not be attending the Council meeting that evening. I met with the Mayor Pro Tem yesterday and the City Administrator today about some things, including the mayoral vacancy. I believe both Terry and Ryan are comfortable with answering questions about the options set out below in my 12/16 email.

The only update or change to this memo is that the Auditor's office through Elections Deputy Nierling prefers the third date to be March 7, instead of February 14, as the Auditor will be out of state for a conference on 2/14. If the Council is going to call for a special election, the Auditor's office would prefer sooner rather than later because of a planned change to voting equipment after the NL mayoral vacancy is filled but, at the same time, recognizes that the timing is up to Council (until March 1) and will work with whatever decision the Council reaches.

Please let Terry, Ryan or me know before the meeting if possible if you have any remaining questions or concerns about the options and procedures.

Scott

From: Scott Peterson
Sent: Friday, December 16, 2016 3:51 PM
To: Annie Pollock <annie.pollock@northlibertyiowa.org>; Brian Wayson <brian.wayson@northlibertyiowa.org>; Alert Chris Hoffman <hoffmanchris5@gmail.com>; Terry Donahue <hzhonor@att.net>; 'Jim Sayre' <jimsayre56@gmail.com>; 'Annie (Obrecht) Pollock (annie-pollock@uiowa.edu)' <annie-pollock@uiowa.edu>
Cc: Tracey Mulcahey <tmulcahey@northlibertyiowa.org>; Ryan Heiar <rheiar@northlibertyiowa.org>; 'amynielsen77@gmail.com' <amynielsen77@gmail.com>
Subject: Another update re mayoral vacancy

All:

With the effective date of the Mayor's resignation expected to be December 31, 2016, and a consensus to next consider and possibly take the next step – whether to appoint a new mayor or call for a special election - at the 1/10/17 Council meeting, I offer the following:

1. SPECIAL ELECTION. If a majority of the Council decides to call for a special election at the 1/10 meeting, the election date should be included as part of the motion.
 - a. There is no requirement for this to be done by resolution, so a motion/second/voice vote is appropriate.

- b. If Council chooses that option on 1/10, the earliest day for special election is the first Tuesday after 32 days later or February 14.
 - c. Per Carrie Nierling, the Elections Deputy at the Auditor's office, the following dates are recommended for Council's consideration in order of the Auditor's preference:
 - i. February 21
 - ii. February 28
 - iii. February 14
2. APPOINTMENT. If a majority of Council decides to appoint a new mayor at the 1/10 meeting, the motion and second should be that the Council intends to appoint a new mayor at the 1/24 meeting.
- a. A decision on 1/10 about council's intent to appoint does not have to specify who might or will be appointed on 1/24.
 - b. There is no requirement for this to be done by resolution, so a motion/second/voice vote is appropriate.
 - c. 1/13/17: Clerk submits notice to the *Leader* about:
 - i. the expected action on 1/24/17; and
 - ii. the right of citizens to petition for special election through February 7.
 - d. 1/19/17: Notice is published in the *Leader* regarding Council's intended action on 1/24 and the additional notice of the right of citizens to file no later than 2/7 a petition calling for a special election.
 - e. 1/24: The Council appoints a new mayor by approval of a motion.
 - f. To call for a special election, the petition needs at least 26 valid signatures of eligible electors (validity of signatures to be determined by the City Clerk).
 - g. The appointment made on 1/24 remains effective until the regular City election in November 2017 or unless a special election is held. If the appointment stands, the winning candidate for mayor in the November election takes office after the official canvas is completed. If a special election is held, the winning candidate in the November election takes office in January 2018 in accordance with the regular timeline and processes laid out by state law.
3. MISCELLANEOUS.
- a. I have set out Paragraphs 1 and 2 based on the Council making a decision to call for a special election on 1/10 or to act on the Council's intent to appoint on 1/24. If the Council decides to take more time, the dates set out above will need to be adjusted.
 - b. The Council has the option to appoint or call for a special election through March 1, 2017. If no decision is made by then, the Auditor is obligated to set a special election.
 - c. An appointment of a new mayor is effective immediately.
 - d. If a Council member is appointed to be the next mayor, the Council member's seat becomes vacant.
 - i. The process to fill that seat is basically the same process set out above but with different dates.
 - ii. The former Council member/newly appointed mayor does not have a right to reclaim his or her old Council seat in the event a special election petition is filed, and a different person wins in that election. However, that individual is eligible:
 - iii. The former Council member is eligible to:
 - 1. to be re-appointment to the Council if the Council so chooses to fill that seat by appointment; and
 - 2. to run in a special election if one is held.
 - e. Based on a recent estimate from the Auditor's office, a special election is likely to cost between \$3,000 and \$5,000.

- f. Any communications about the mayoral vacancy and the two options before the Council are fully subject to Open Meetings (Chapter 21) and Open Records (Chapter 22) laws.

I know this is a lot to throw at you, but hopefully it is a helpful guide. As I have received approval for vacation and plan to be in Portland January 7-11 to visit family, I would like to try to answer any questions or address any concerns you might have between now and Friday, January 6, as best as I can. And if you have any points about corrections or clarifications of any provisions, please get ahold of me as soon as is practicable.

Scott C. Peterson
City Attorney, City of North Liberty
3 Quail Creek Circle
P.O. Box 77
North Liberty, IA 52317
319-626-5767

Additional Information

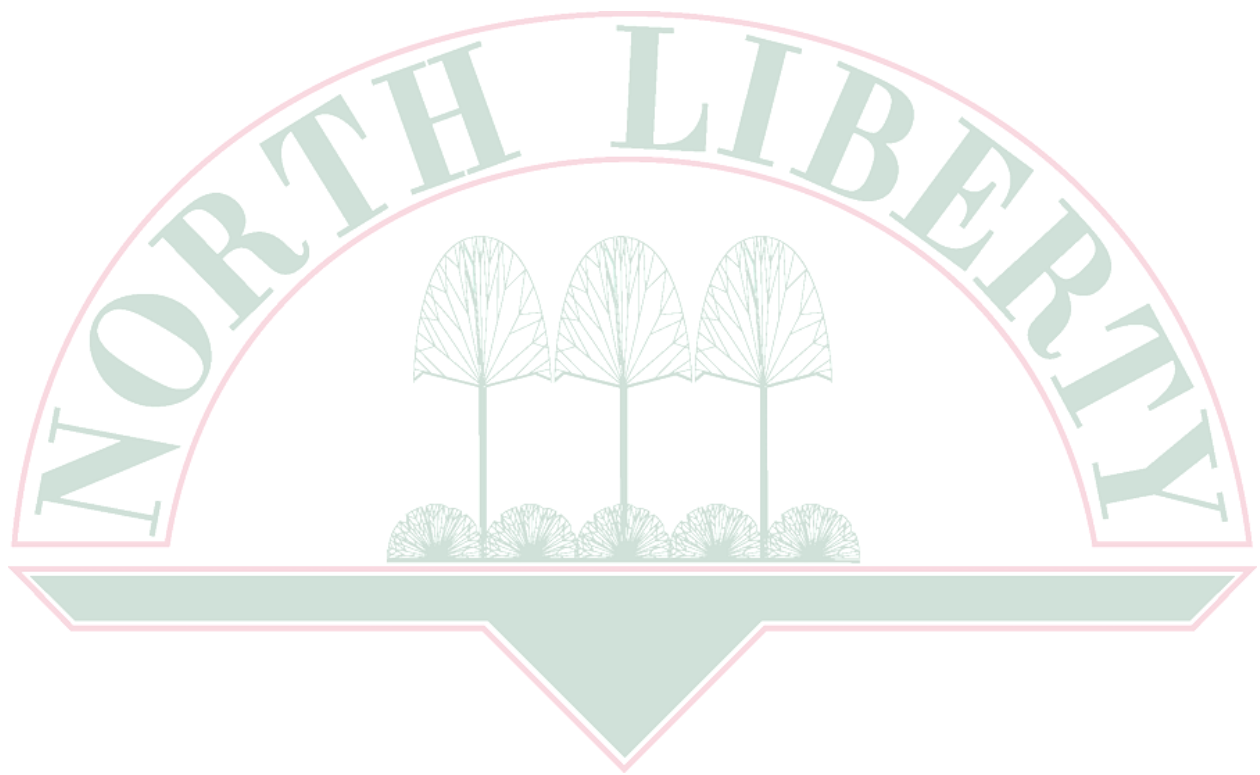



Quarterly Sustainability Report January 2017

This report provides a summarization of the improvements implemented in each department as a result of participation in the City Energy Management Program. All City buildings were subjected to an energy audit. The most cost effective projects were identified and implemented. Each quarter, Council will be provided with a status report on the implementation of these projects. On the included graphs, electric usage is designated in red and natural gas is blue. The yellow benchmark line represents the expected usage based on the type of use of the facility. The benchmark is basically an average of other buildings of similar usage to compare North Liberty’s building. The software used to generate the charts is called B3 Benchmarking. City staff has been entering data on gas and electric use since 2008.

Police Department

The Police Department has made no additional modifications since the last report.

This chart represents the historical view of gas and electric usage in the police department. The chart is not normalized for weather. Electric use in the most recent months is less than it was for last year at that time.

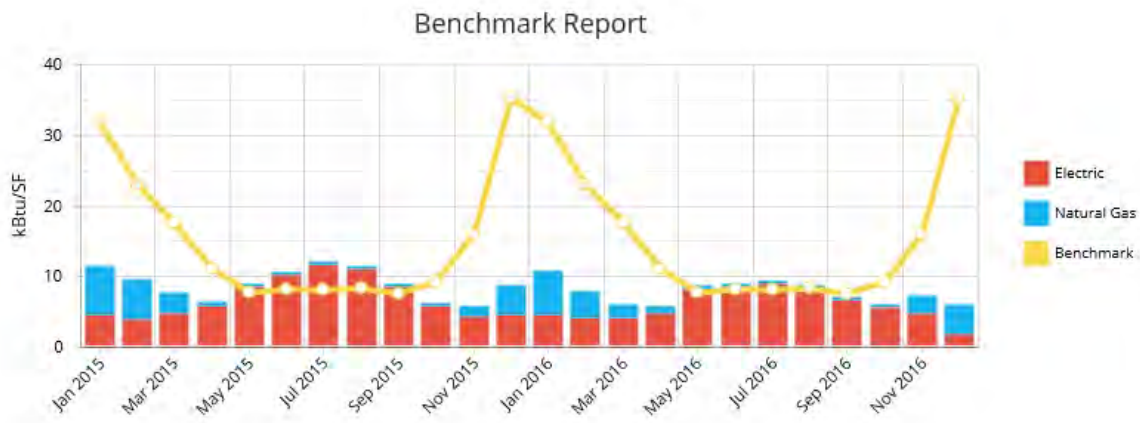

Library

The Library is still working on the LED change out program. Staff is working on adding LED lighting to the main hallway.

Community Center

The Community Center has changed out the pool lights to LED.

A review of the above chart shows the reduction in energy use from the year previous. This chart is not normalized for weather.

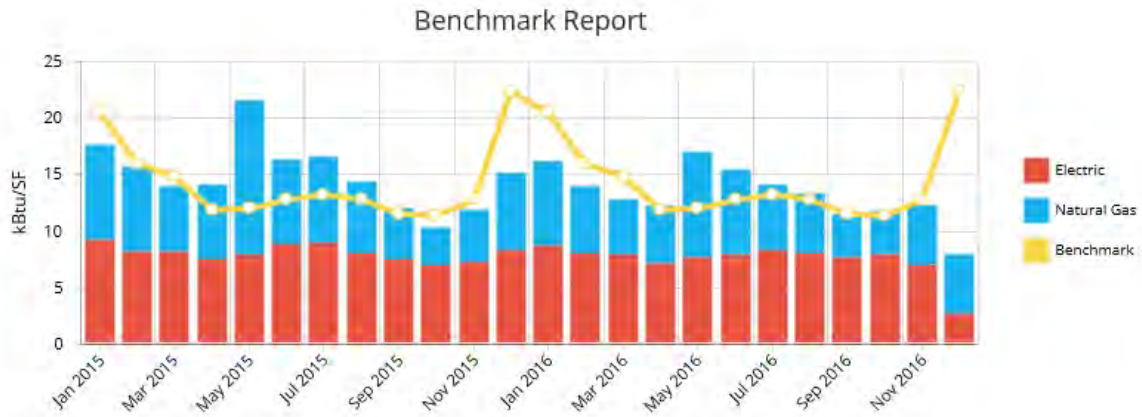

Streets Department

Four streetlights were retrofitted with LED light bulbs.

This building, being newer construction, has a very low energy usage. The difference between the benchmark and actual use is significant.

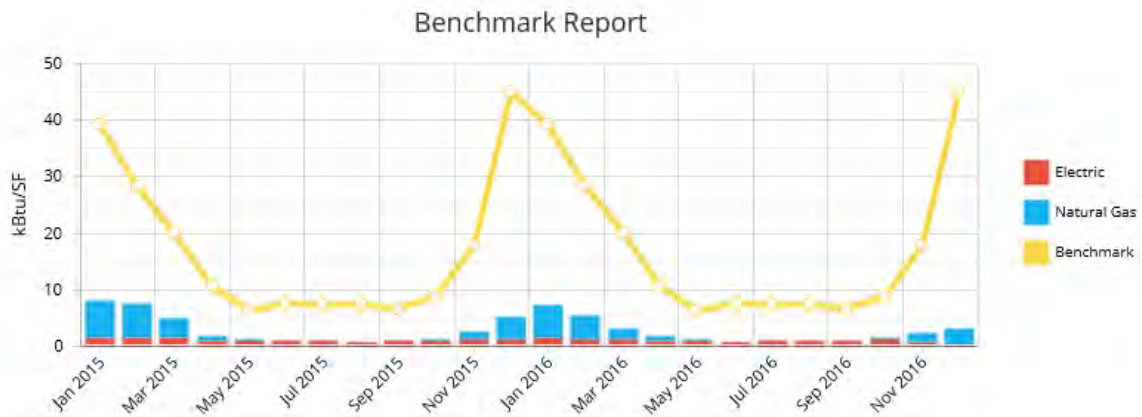

Parks Department

The Parks Department has not made any new significant changes.

The Parks Department has an older facility. Their usage, even though minor, has been reduced.

Benchmark Report

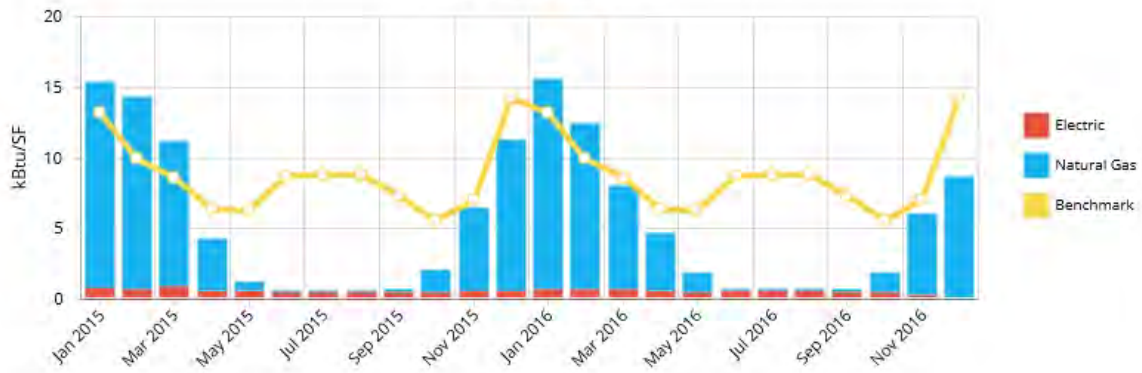

Fire Department

Benchmark Report

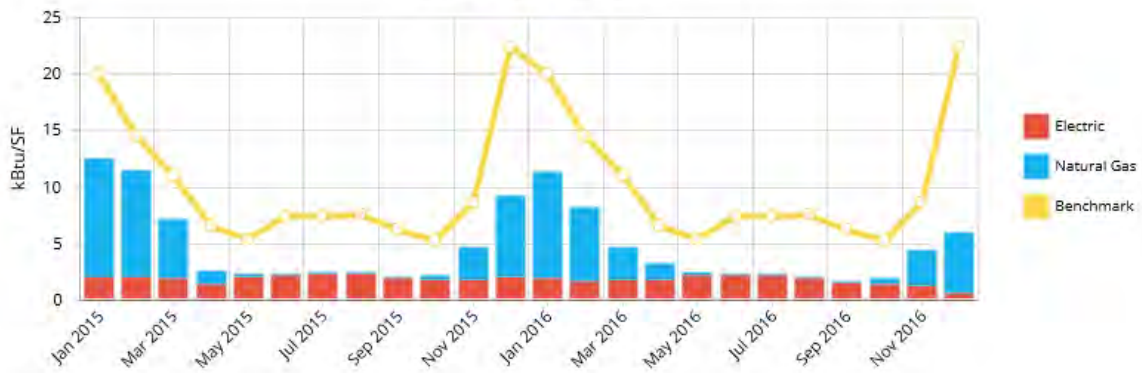

Water Department

The usage shown in the chart below is operational, not just building functions. As water consumption increases, energy consumption increases. The software used for this process does not benchmark operational functions.

Benchmark Report

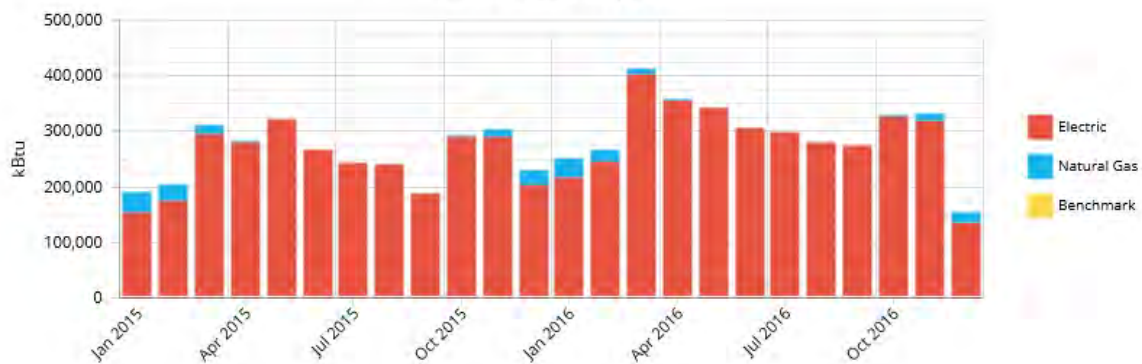

Wastewater Department

The usage shown in the chart below is operational, not just building functions. As water consumption increases, energy consumption increases due to the increased sewer demand. The

software used for this process does not benchmark operational functions. It is expected that energy use will increase as expansion increases the footprint of the facility and increases the operating costs.

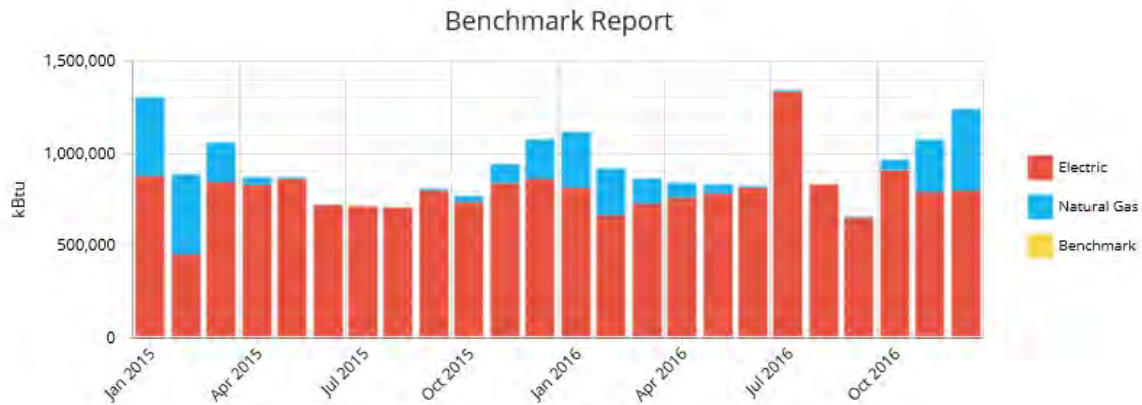

Weather normalization affects many of the utility uses. Unfortunately, this software does not have weather normalization functionality at this time.

Other Sustainability Achievements

The big achievement this quarter is the installation and operation of the solar panel systems at the Fire Department, Streets Shop and Parks Shop facilities. Reports on the functionality and production will soon be available online. When the website is implemented, the link will be provided to the Council and the public.

The City's curbside composting program continues to slowly grow. 133 households are participating in the program.

If you have questions regarding this document or would like additional information, please contact Tracey Mulcahey.



Monthly Report Summarization

December 31, 2016

This report provides a summarization of the budget status after the end December, 2016. At the end of this month, the City is 50% through the budget year. The red line indicates the percentage where the budget area is and green/blue line is the percentage of the budget year. Any particular area falling approximately 10% below or above the percentage of the budget year will be explained below.

Revenues: The following chart demonstrates the condition of the City's budgeted revenues as of December 31, 2016:

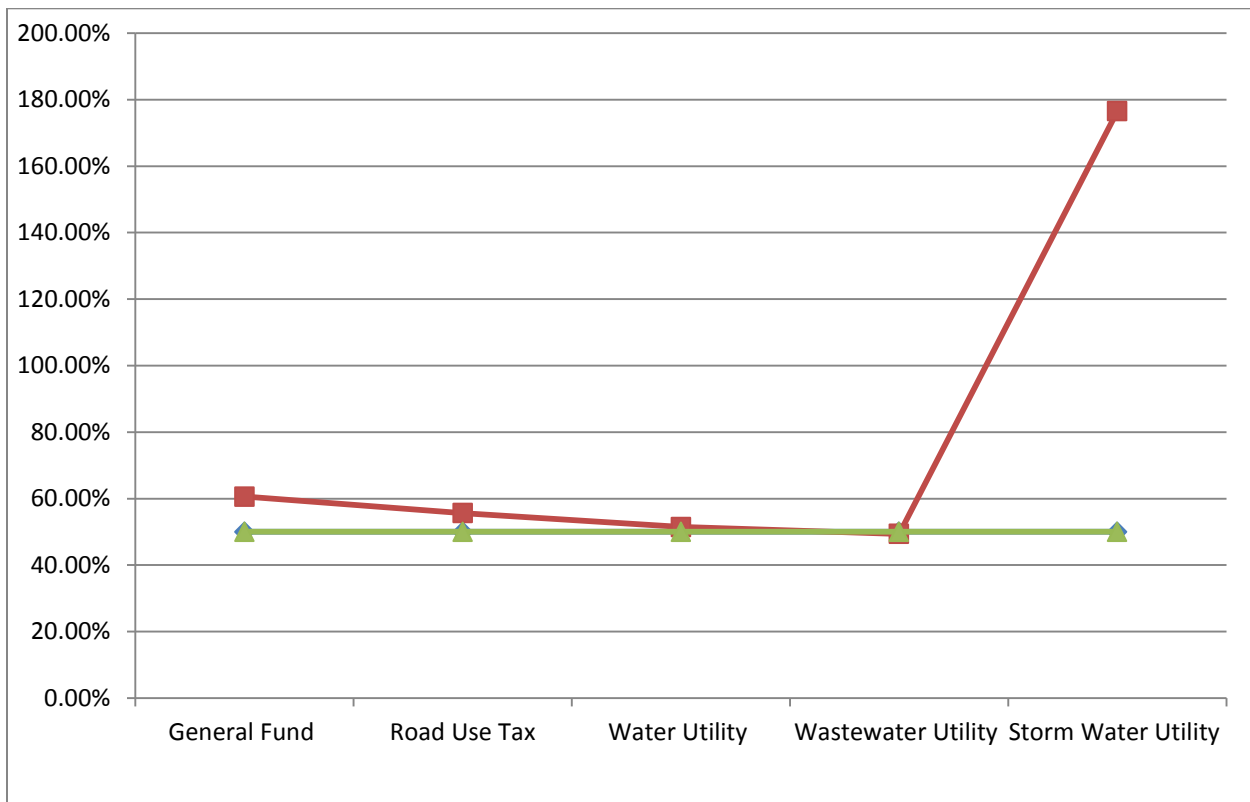

- This chart represents the historical view at the end of November. The City received the first half of the property tax revenue in October and will receive and the second half in April.
- Stormwater revenues are significantly higher than budgeted due to the SRF Sponsored Water Quality Soil Quality Restoration Project reimbursement.

Overall revenues for the year to date are \$22,929,192.23, 37.24% of the budgeted amount. This amount is less than the budgeted mark. Projected borrowing will bring this number in line with projected amounts.

Expenditures: The following chart demonstrates the condition of the City’s budgeted expenditures as of December 31, 2016:

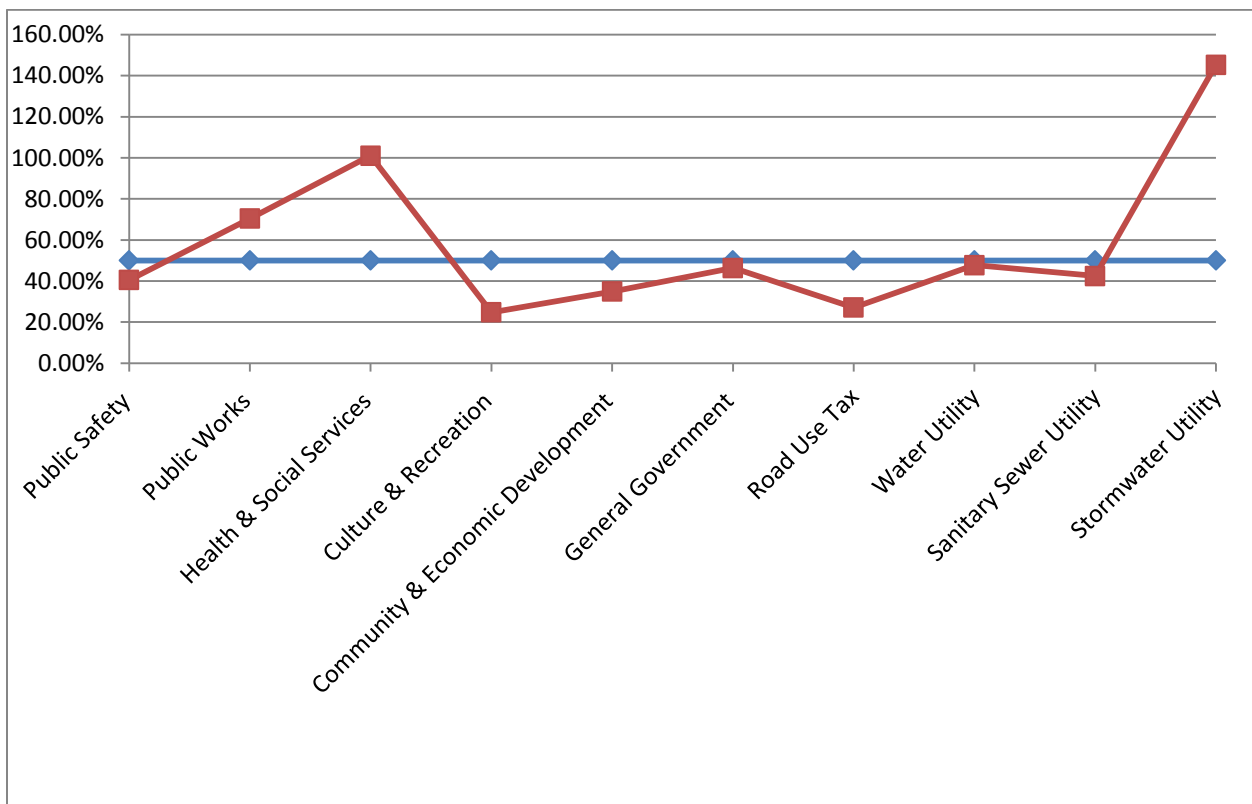

- Public works is higher than expected due to the volume of garbage sticker and bin costs paid in July and August along with the increased costs paid to Johnson County Refuse for recycling.
- Health and Social Service expenses are higher due to the payment to the Food Pantry and the School Family Resource Centers and other social service commitments in July and August.
- Culture and Recreation expenditures are lower than expected to the quantity of end of year transfers in these departments.
- Road Use Tax expenditures are lower than expected due to end of year transfers.

- Stormwater Utility expenses are higher than projected due to the Soil Quality Restoration Program.

Year to date total expenditures are \$22,195,439.17 or 36.76% of the projected budget amounts. This amount is less than the 50% of the fiscal year completed due to expenditures occurring later in the fiscal year.

Following is the Treasurer’s Report for December. The General Fund Balance is comprised of more than just the 010 General Fund. For accounting purposes of the budget and reporting, other funds such as Library Capital, Fire Capital and others are incorporated into the General total. The General Fund for operating expenses has a fund balance of \$ 5,550,101.69. The other funds in the total shown here are obligated to specific departments or types of activities. The other funds are separated out to keep those obligations clear for future expenditures.

CITY OF NORTH LIBERTY
TREASURER'S REPORT
December 31, 2016

FUNDS	BALANCE FORWARD 12/01/2016	REVENUE	EXPENSE	BALANCE ENDING 12/31/2016
GENERAL	8,114,222.49	2,064,226.82	-1,245,661.91	8,932,787.40
SPECIAL REVENUE	5,689,048.64	154,011.41	-60,915.35	5,782,144.70
DEBT SERVICE	768,691.34	8,601.01	-419,762.75	357,529.60
CAPITAL PROJECTS	-5,041,477.36	210.49	-135,446.40	-5,176,713.27
WATER ENTERPRISE	3,896,414.07	356,652.47	-596,271.65	3,656,794.89
WASTEWATER ENTERPRISE	-167,255.92	1,411,652.51	-1,009,171.92	235,224.67
STORM WATER ENTERPRISE	219,602.42	16,349.15	-44,259.07	191,692.50
TOTAL	13,479,245.68	4,011,703.86	-3,511,489.05	13,979,460.49

If you have questions regarding this document or would like additional information, please contact Tracey Mulcahey.